

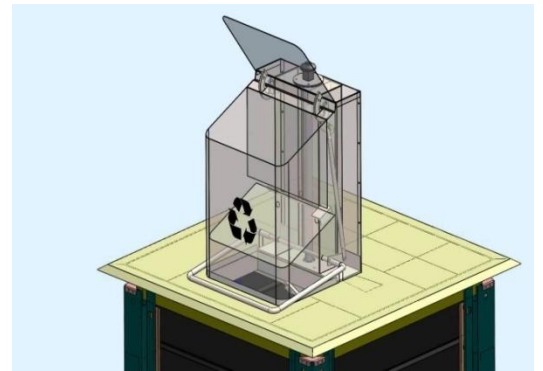

Bhopal Smart City Development Corporation Limited



REQUEST FOR PROPOSAL

September 2018

“Supply and Installation of Modern Fully Underground Waste Collection System by Using Smart Bins for Collection of Municipal Solid Waste at Designated Locations in Bhopal City other related Miscellaneous works along with Collection and Transfer of Waste during Operation and Maintenance Period of Five Years”

(Second Call)

Prepared by

Recommended by

Approved by

CONTENTS

SECTION 1	Notice Inviting Tender (NIT)
	Memorandum (Annexure 1)
SECTION 2	Instructions to the Bidders (ITB)
SECTION 3	Clauses of the Contract
SECTION 4	Labor Safety Provisions
SECTION 5	Forms and Formats
SECTION 6	Scope of Work &Special Conditions of the Contract (SCC)
SECTION 7	Technical Specifications and List of Approved Makes
SECTION 8	Drawings
SECTION 9	Bill of Quantities (BOQ)

SECTION-1
NOTICE INVITING TENDER

BHOPAL SMART CITY DEVELOPMENT CORPORATION LIMITED

NOTICE INVITING TENDER (NIT)

BSCDCL invites online item rate tender as per schedule as under:

Tendering Document No.	: MPBSCDCL/TENDER NO -70
Name of the Work	: Supply and Installation of Modern Fully Underground Waste Collection System by Using Smart Bins for Collection of Municipal Solid Waste at Designated Locations in Bhopal City other related Miscellaneous works along with Collection and Transfer of Waste during Operation and Maintenance Period of Five Years (Second Call)
Brief Scope of Work	: Supply and Installation of Modern Fully Underground Waste Collection System by Using Smart Bins for Collection of Municipal Solid Waste at Designated Locations in Bhopal City other related Miscellaneous works along with Collection and Transfer of Waste during Operation and Maintenance Period of Five Years on Procurement and Construction Basis including Preparation of Working Drawings.
Estimated Cost	: 13,55,46,263/- (Thirteen Crore Fifty Five Lakhs Forty Six Thousand Two Hundred and Sixty Three Rupees)
Period of Completion	: 6 Months (CAPEX) and 60 months (OPEX)
Earnest Money Deposit	: 7,00,000/- (Seven Lakhs Rupees)
Non-refundable cost of e-Tender Document	: 30,000/- (Thirty Thousand Rupees)
Purchase of Tender Start Date	: 06.09.2018 at 17:30Hrs
Purchase of Tender End Date	: 21.09.2018 at 23:00Hrs
Last date & time of submission of Online Tender	: 21.09.2018 at 23:30Hrs
Period during which hard copy of the documents as per NIT shall be submitted.	: 22.09.2018 at 11:00Hrs
Date & Time of Opening of technical Bid	: 22.09.2018 at 13:00Hrs
Date & Time of Opening of Financial Bid	: Will be intimated to the successful bidders.
Validity of offer	: 90 days from the date of opening of price bid.
Pre-Tender Meeting & Venue	: 12.09.2018 at 15.00 Hrs At BSCDCL, Bhopal Office

The tender document can be downloaded from www.mpeproc.gov.in “**Corrigendum, if any, would appear only on the www.mpeproc.gov.in web site and not to be published in any News Paper**”.

- The intending Bidder must read the terms and conditions of BSCDCL carefully. He should only submit his tender if he considers himself eligible and he is in possession of all the documents required.
 - a) Information and Instructions for Bidder posted on Website(s) shall form part of Tender Document.
- The Tender Document as uploaded can be viewed and downloaded free of cost by anyone including intending Bidder. But the tender can only be submitted after uploading the mandatory scanned documents such as
 - a) Proof of e-payment towards cost of tender document,
 - b) Proof of online payment through e-portal www.mpeproc.gov.in/ Bank Guarantee of any Nationalized or Commercial Scheduled Bank against EMD in favor CEO, BSCDCL & All other documents shall be as per Notice Inviting e-tender.
- The Bidders are required to quote strictly as per terms and conditions, specifications, standards given in the tender documents and not to stipulate any deviations.
- After submission of the tender the Bidder can re-submit revised tender any number of times but before last time and date of submission of tender as notified.
- When it is desired by BSCDCL to submit revised financial tender then it shall be mandatory to submit revised financial tender. If not submitted then the tender submitted earlier shall become invalid.
- On opening date, the Bidder can login and see the tender opening process.
- Bidder can upload documents in the form of JPG format and PDF format
- Bidder has to upload scanned copies of all the documents including valid GST registration, PAN NO, TAN NO. as stipulated in the tender document.
- If the bidder is found ineligible after opening of tenders, his tender shall become invalid and cost of tender document and processing fee shall not be refunded.
- If any discrepancy is noticed between the documents as uploaded at the time of submission of tender and hard copies as submitted physically by the contractor the tender shall become invalid and cost of tender document and processing fee shall not be refunded.
- Notwithstanding anything stated above, BSCDCL reserves the right to assess the capabilities and capacity of the Bidder to perform the contract, in the overall interest of BSCDCL. In case, Bidder's capabilities and capacities are not found satisfactory, BSCDCL reserves the right to reject the tender.
- Certificate of Financial Turn over: At the time of submission of tender, the tender shall upload Certificate from Chartered Accountant mentioning Financial Turnover of last 3 years or for the period as specified in the tender document and further details if required may be asked from the Bidder after opening of technical tenders. There is no need to upload entire voluminous balance sheet.

The Bidder if required can submit queries in writing on E-mail address.
tenderqueries@smartbhopal.city before 11.09.2018 up to 13.00 hrs.

MEMORANDUM

Sl. No.	Description	Cl. No. of NIT/ITT/Clauses of Contract (CC)	Values/Description to be Applicable for Relevant Clause(S)
1)	Name of Work		Supply and Installation of Modern Fully Underground Waste Collection System by Using Smart Bins for Collection of Municipal Solid Waste at Designated Locations in Bhopal City other related Miscellaneous works along with Collection and Transfer of Waste during Operation and Maintenance Period of Five Years on Procurement and Construction Basis including Preparation of Working Drawings.(Second Call)
2)	Client/Owner		Bhopal Smart City Development Corporation Limited.
3)	Type of Tender		Percentage rate / Item Rate tender
4)	Earnest Money Deposit		7,00,000/- (Seven Lakhs Rupees)
5)	Estimated Cost(PAC)		13,55,46,263/- (Thirteen Crore Fifty Five Lakhs Forty Six Thousand Two Hundred and Sixty Three Rupees)
6)	Time allowed for Completion of Work		6 Months (CAPEX) and 60 months (OPEX)
7)	Mobilization Advance		10% of contract value
8)	Interest Rate of Mobilization Advance		Simple Interest Rate of 10 % (Percent only) (Per Annum)
9)	Schedule of rates Applicable		NON SOR, UADD/MPPWD/PWD SOR(if Applicable for civil work)
10)	Validity of Tender		90 (Ninety) Days
11)	Performance Guarantee		10 % (Ten Percent Only) of contract value within 30 days from the issue of Letter of Award. Which will be release after successful completion of O&M period ie 5 Years.
12)	Security Deposit/Retention Money		Not applicable
13)	Operation and Maintenance Period		Five (5) years after successful commissioning of all Tendered works
14)	Time allowed for starting the work		The date of start of contract shall be reckoned from 10 days after the date of issue of letter of Award .
15)	Defect Liability Period		12 month from the date of taking over of the work by the BSCDCL or time allowed whichever is earlier.

MANDATORY PROPOSAL (Envelope A)

1. Earnest Money Deposit(EMD)
2. Cost of Document
3. Letter of Acceptance of tender condition as per format enclosed innexure-
II. (*SECTION-5 Forms and Format)

TECHNICAL PROPOSAL (Envelope B)

[PRE-QUALIFICATION CRITERIA FOR BIDDERS]

1. Sole Bidder/Consortium members (each consortium member) should be a company registered under Indian Companies Act 1956/2013 or a Partnership Firm registered under Indian Partnership Act 1932 or proprietary firm or a Limited Liability Partnership registered under LLP Act 2008.
2. The Average annual financial turnover for last 3 years (2015-16, 2016-17, 2017-18) shall be at least 30% of the estimated cost put to tender, Copies of balance sheets of last three financial years duly certified by a Chartered Accountant shall be submitted in support of the requisite financial Turnover.
3. The bidder shall have successfully completed similar nature of works in Government sector during the last seven years as mentioned below:

Three similar works each costing not less than 40% of the estimated cost put to tender

OR

Two similar works each costing not less than 50% of the estimated cost put to tender

OR

One similar work costing not less than 80% of the estimated cost.

Similar nature of work includes Installation of Modern Underground/Semi Underground Bins, Collection of Municipal Waste.

4. Net worth should be positive in past year i.e. FY 2017-2018.
5. Bidder should have GST Registration, EPF Registration Certificate & PAN Card, TAN No, ESIC certificate.(a. Information regarding the constitution of the Applicant/firm e.g. Proprietary, Partnership, Private Ltd. etc. along with proof of the same such as copies of registration/ partnership deed etc.)
6. (a) The Bidder may be a single entity or Consortium, coming together to Implement the Project.
(b) Bidder may be a natural person, private entity, or any combination of them with a formal intent to enter into a Consortium agreement or under an existing agreement to form a Consortium. A Consortium shall be eligible for consideration subject to the conditions.
(c) In case of consortium the Members limited to 2 (1+1), The experience and Financial both shall be considered jointly.
7. Joint Ventures (JV) are not allowed.

The copy of above documents shall be submitted by the Bidder along with the hard copies of other required documents and the following list of Documents to be scanned and uploaded within the period of tender submission:

- Proof of online payment / Bank Guarantee of any Nationalized or all commercial Scheduled Bank against EMD in favor of CEO, BSCDCL.
- Copy of documents related to qualifying requirement of bidders as per NIT clause.
- Certificate of Financial Turnover duly certified by CA as indicated above.
- Acknowledgement towards cost of tender fee submission.
- All pages of the entire Corrigendum (if any) duly signed by the authorized person.

FINANCIAL PROPOSAL (Online only)

1. Bidders who will be found Eligible in **Mandatory & Technical Proposals**, only those Bidder's financial proposals will be opened.
2. The tender will be awarded to the Bidder with the lowest quoted rate (L1) against the Probable Amount of Contract (PAC).
3. Bidders who will not be found eligible in **Mandatory "OR" Technical Proposals**, they will be rejected and their Financial Proposals will not be opened.

INSTRUCTIONS FOR FINANCIAL BID SUBMISSION-

- Quote should be in percentage higher or below on the SOR Rates the same is to quoted in the form of decimal only. For example if contractor wants to quote 5 percent higher than he have to quote 1.05 and if he wants to quote 5 % (percent) below he have to quote 0.95 in given column of financial bid sheet and so on.....
- Financial Bid format is uploaded in Excel Format in www.mpeproc.gov.in. At the time of financial bidding, bidder is requested to download the file, and update the same.
- For Non SOR items bidder can quote for individual item rates in respective financial bid sheet.
- Bidders are requested to check final figure in all the totals of all sheets. BSCDCL is not responsible for errors in the financial bid document.
- Any Excel cell if left blank then it will be considered as Zero“0”.
- Bidders are required to upload the updated financial bid in the prescribed excel Format in the www.mpeproc.gov.in at the time of final financial bid submission.

SECTION-2
INSTRUCTIONS TO BIDDER

INSTRUCTION TO BIDDER (ITB)

A. GENERAL INSTRUCTIONS:

2.1. General terms of Bidding-

2.1.1.1 No Bidder shall submit more than one BID for the Project.

2.1.13 The contractor is to give the guarantee for Five year against all installation and equipment defects.

2.1.14 Deleted

2.1.15 The successful bidder needs to submit performance guarantee 10% (Ten per cent) of the quoted price, which will be released after successful completion of O&M period ie. 5 years.

2.1.16 Deleted.

2.1.17 Deleted.

2.1.18 The Rate should be quoted by the bidder shall be Excluding GST (i.e. If applicable GOODS AND SERVICE TAX PAID SEPERATELY) . Applicable taxes/TDS shall be deducted.

2.1.19 All the Civil work Should be repaired with original material including coloring if any breakage or dismantling work is done during installation of the system, including cleaning of the site, for which no extra payment shall be made to the contractor.

2.1.1.10 The rates to be given for furnished complete work, all material, labor wastage, royalties, taxes, lease rent, scaffolding, transportation charges, breakage, making good any damage to wall, ceiling, fitting etc, to make the original finish including painting, transportation, replacement, of any defective material, theft, insurance, variation in market rates, removal of rubbish dismantled material, cleaning of site be included in the quoted rates.

2.1.1.11 The contractor is to arrange for storage of material & its Security arrangement during the installation & commissioning of work.

2.1.1.12 The contractor should submit the one year defective part replacement guarantee, caused due to any reason after Five year maintenance services of the system for which no extra payment will be made except quoted rate.

2.1.1.13 The contractor will be fully responsible for any accident, damages, losses, that occurs during the installation & commissioning of work. No compensation will be made by the BSCDCL.

2.1.1.14 The contractor is to take all measures for safety and security for man & material and also to follow all labor laws.

2.1.1.15 The contractor should be registered in EPF & ESIC & necessary certificate of registration shall be submitted during tendering.

2.1.1.16 The Rates should be quoted FOR at site Bhopal.

212 The Feasibility Report / Preliminary Project Report of the Project has been assessed however the Bidders are expected to carry out their own surveys, investigations and other Preliminary examination of the Project before submitting their Bids. Nothing contained in the attached drawings/BOQ shall be binding on the BSCDCL nor confer any right on the Bidders, and the BSCDCL shall have no liability whatsoever in relation to or arising out of any or all contents of TENDER.

213 Notwithstanding anything to the contrary contained in this RFP, the Preliminary terms specified in the draft Agreement shall have overriding effect; provided, however, that any conditions or obligations imposed on the Bidder hereunder shall continue to have effect in addition to its obligations under the Agreement.

214 Deleted.

215 The Bidder shall deposit a BID Security (EMD) of Rs. 7.00 Lakhs (Seven Lakhs only) in accordance with the provisions of this RFP.

Company Name- Bhopal Smart City Development Corporation Limited

Bank Name- Allahabad Bank

Branch Address- Arera Colony Bhopal

A/C No.- 50327343809

IFSC Code- ALLA0210197

PAN No. - AAGCB6537N

TIN No.- 23889236926

Service Tax No. -AAGCB6537NSD001

GST No.- 23AAGCB6537N1ZE

a) Tender Document fee should be.

b) EMD should be submitted online or in the form of Bank Guarantee/Online/Demand Draft (DD)/FDR of Nationalized or Commercial Schedule Bank in favor CEO, BSCDCL.

c) Performance Guarantee should be submitted in the form of Bank Guarantee/FDR of any Nationalized or Commercial Scheduled Bank in favor CEO, BSCDCL.

216 The validity period of the Bank Guarantee, shall not be less than 180 (one hundred and eighty) days from the BID Due Date, inclusive of a claim period of 60 (Sixty) days, and may be extended as may be mutually agreed between the BSCDCL and the Bidder.

217 The BID shall be summarily rejected if it is not accompanied by the BID Security. The BID Security shall be refundable no later than 150 (one hundred and fifty) days from the BID Due Date except in the case of the Selected Bidder whose BID Security shall be retained till it has provided a Performance Security under the Agreement.

218 The Bidder should submit a Power of Attorney as per the format at Appendix-III, Authorizing the signatory of the BID to commit the Bidder.

219 Any condition or qualification or any other stipulation contained in the BID shall render the BID liable to rejection as a non-responsive BID.

2.1.10 The BID and all communications in relation to or concerning the Bidding Documents and the BID shall be in English language.

2.1.11 The documents including this RFP and all attached documents, provided by the BSCDCL are and shall remain or become the property of the BSCDCL and are Transmitted to the Bidders solely for the purpose of preparation and the submission of a BID in accordance herewith. Bidders are to treat all information as strictly confidential and shall not use it for any purpose other than for preparation and submission of their BID. The provisions of this Clause shall also apply mutatis mutandis to BIDs and all other documents submitted by the Bidders, and the BSCDCL will not return to the Bidders any BID, document or any information provided along there with.

2.1.12 This RFP is not transferable.

2.1.13 Any award of Project pursuant to this RFP shall be subject to the terms of Bidding Documents and also fulfilling the criterion as mentioned in clause while bidding is open to persons from any country, the following provisions shall apply then the Eligibility of such Bidder shall be subject to approval of the BSCDCL from national security and public interest perspective. The decision of the BSCDCL in this behalf shall be final and conclusive and binding on the Bidder. The holding or acquisition of equity or control, as above, shall include direct or indirect holding/ acquisition, including by transfer, of the direct or indirect legal or beneficial ownership or control, by persons acting for themselves or in concert and in determining such holding or acquisition, the BSCDCL shall be guided by the principles, precedents and definitions contained in the Securities and Exchange Board of India (Substantial Acquisition of Shares and Takeovers) Regulations, 1997, or any substitute thereof, as in force on the date of such acquisition. The Bidder shall promptly inform the BSCDCL of any change in the shareholding, as above, and failure to do so shall render the Bidder liable for disqualification from the Bidding Process.

2.1.14 Notwithstanding anything to the contrary contained herein, in the event that the Bid Due Date falls within three months of the closing of the latest financial year of a Bidder, it shall ignore such financial year for the purposes of its Bid and furnish all its information and certification with reference to the 5 (five) years or 1 (one) year, as the case may be, preceding its latest financial year. For the avoidance of doubt, financial year shall, for the Purposes of a Bid hereunder, mean the accounting year followed by the Bidder in the course of its normal business.

2.1.15 Any entity which has been barred by GOI or Govt of Madhya Pradesh, ISC and EI works, and the bar subsists as on the Bid Due Date, would not be eligible to submit the BID.

2.1.16 The BSCDCL reserves the right to reject an otherwise eligible bidder on the basis of the information given in this tender document. The decision of the BSCDCL in this case shall be final.

2.1.17 2.2 Eligibility and qualification requirements of Bidder

2.2.1 For determining the eligibility of Bidder the following shall apply:

- (a) The Bidder may be a single entity or Consortium, coming together to implement the Project.
- (b) Bidder may be a natural person, private entity, or any combination of them with a formal intent to enter into a Consortium agreement or under an existing agreement to form a Consortium. A Consortium shall be eligible for consideration subject to the conditions.
- (c) An Bidder shall not have a conflict of interest (the "Conflict of Interest") that affects the

Bidding Process. Any Bidder found to have a Conflict of Interest shall be disqualified and liable for forfeiture of the BID Security or Performance Security as the case may be. A Bidder shall be deemed to have a Conflict of Interest affecting the Bidding Process, if:

(d) A Bidder shall be liable for disqualification and forfeiture of BID Security, if any legal, financial or technical adviser of the BSCDCL in relation to the Project is engaged by the Bidder, its Member or any Associate thereof, as the case may be, in any manner formatters related to or incidental to such Project during the Bidding Process or subsequent to the (i) issue of the LOA or (ii) execution of the Agreement. In the even though such adviser is engaged by the selected Bidder or Contractor, as the case may be, after issue of the LOA or execution of the Agreement for matters related or incident alto the project, then notwithstanding anything to the contrary contained herein or in the LOA or the Agreement and without Prejudice to any other right or remedy or the BSCDCL, including the forfeiture and appropriation of the BID Security or Performance Security, as the case may be, which the BSCDCL may have there under or otherwise, the LOA or the Agreement, as the case may be, shall be liable to be terminated without the BSCDCL being liable in any manner whatsoever to the Selected Bidder or Contractor for the same. For the avoidance or doubt, this disqualification shall not apply where such adviser was engaged by the Bidder, its Member or Associate in the past but its assignment expired or was terminated 6 (six) months prior to the date of issue of this RFP. Nor will this disqualification apply where such adviser is engaged after a period of 3 (three) years from the date of commercial operation of the Project.

OTHER INSTRUCTIONS:-

The pre-qualification / enlistment of the contractors should be valid on the last date of submission of tenders. In case the last date of submission of tender is extended, the pre-qualification of contractor should be valid on the original date of submission of tenders. The tender document as uploaded can be seen on website www.mpeproc.gov.in and can be downloaded free ofcost.

Mode of Submission: Earnest Money Deposit

Earnest Money Deposit of amount as mentioned in “NIT/ Memorandum (Annexure-I)” required to be submitted online only or Bank Guarantee from any Nationalized or all Commercial scheduled banks in the enclosed format. The EMD shall be valid for minimum period of 150 (One Hundred Fifty) days from last day of submission of Tender. **The EMD shall be scanned and uploaded to the e-Tendering website within the period of tender submission and original should be deposited in office of BSCDCL**

The EMD of all unsuccessful Bidders will be returned within thirty (30) days of the Award of the contract to successful Bidder or after the receipt of their BGs verified from the Zonal office of the issuing Bank, whichever is later. No interest will be payable by the BSCDCL on the said amount covered under EMD/Any other performance guarantee.

Interested contractor who wish to participate in the tender has also to make following payments through online payment only.

Cost of Tender Document – Rs. 30,000/-To be submit online only/- e- Tender Processing Fee – As applicable for MPEPROC portal.

EMD/ Tender document fees should be submitted online or in the form of Bank Guarantee against EMD, Cost of Tender Document and, e-Tender Processing Fee online payment receipt accordingly, shall be placed in single sealed envelope superscripted as “Earnest Money, Cost of Tender Document and Cost of e-Tender Processing Fee” with name of work and due date of opening of the tender also mentioned thereon.

Copy of pre-qualification/enlistment letter and certificate of work experience (if required) and other documents as specified in the tender shall be scanned and uploaded to the e-Tendering website within the period of tender submission and certified copy of each shall be deposited in a separate envelope marked as “Other Documents”.

Both the envelopes shall be placed in another envelope with due mention of Name of work, date & time of opening of tenders and to be submitted in the office of BSCDCL after last date & time of submission of tender.

Online technical tender documents submitted by intending Bidders shall be opened only of those Bidders, who’s Earnest Money Deposit, Cost of Tender Document and e-Tender Processing Fee and other documents placed in the envelope are found in order. The Price tender of those Bidders whose documents found to be in order shall be opened. The date of opening of price tender shall be informed to the Bidder.

The tender submitted shall become invalid if:

- The Bidder is found ineligible/if any document is found fake.
- The Bidder does not upload all the documents (including GST registration) as stipulated in the tender document.
- If any discrepancy is noticed between the documents as uploaded at the time of submission of tender and hard copies as submitted physically in the office of tender opening authority.

VALIDITY OF TENDER

The tender for the works shall remain open for acceptance for a period of Ninety (90) days from the date of opening of financial tender. If any Bidder withdraws his tender before the said period or issue of letter of acceptance, whichever is earlier, or makes any modifications in the terms and conditions of the tender which are not acceptable to the BSCDCL, then the BSCDCL shall, without prejudice to any other right or remedy, be at liberty to forfeit the said earnest money as aforesaid. Further the Bidders shall not be allowed to participate in the retendering process of work.

ACCEPTANCE OF TENDER

BSCDCL reserves the right to reject any or all the tenders in part or full without assigning any reason whatsoever. BSCDCL does not bind itself to accept the lowest tender. The BSCDCL reserves the right to award the work to a single party or split the work amongst two or more parties as deemed necessary without assigning any reason thereof. The Contractor is bound to accept the part work as offered by BSCDCL after split up at the quoted/negotiated rates.

The tenders shall be strictly as per the conditions of contract. Tenders with any additional condition(s)/modifications shall be rejected.

The witnesses to the Tender/Contract Agreement shall be other than the Bidder/ Bidders competing for this work and must indicate full name, address, and status/occupation with dated signatures.

The acceptance of tender will rest with the BSCDCL who does not bind itself to accept the lowest tender and reserves to itself the right to reject any or all the tenders received without assigning any reason thereof. Tenders in which, any of the prescribed conditions are not fulfilled or found incomplete in any respect are liable to be rejected.

On acceptance of tender, the name of the accredited representative(s) of the contractor who would be responsible for taking instructions from Engineer-in-Charge or its authorized representative shall be intimated by the contractor within 07 days of issue date of letter of Awards by BSCDCL.

The Bidder shall not be permitted to tender for works if his near relative is posted in the project office or concerned Zonal Office of the BSCDCL. The contractor shall also intimate the names of persons who are working with him in any capacity or are subsequently employed by him and who are near relatives to any of the officers in BSCDCL. Any breach of this condition by the Bidder would render him liable to the withdrawal of the work awarded to him and forfeiture of Earnest Money. This may also debar the contractor from tendering for future works under BSCDCL.

For the purpose of operation of this clause a near relative shall mean wife, husband, parents, grandparents, children, grandchildren, brothers, sisters, uncles, aunts, cousins and their corresponding in-laws

The time of completion of the entire work, as contained in contract shall be as mentioned in "Memorandum - Annexure-I", which shall be reckoned from the 10th day after issue of the letter of Award by the BSCDCL. Canvassing whether directly or indirectly, in connection with Bidders is strictly prohibited and the tenders submitted by the contractors who resort to canvassing will be liable for rejection.

The tender award, execution and completion of work shall be governed by tender documents consisting of (but not limited to) Letter of Award/Letter of work order, Bill of Quantities, Special Conditions of Contract, General Conditions of Contract, Specifications & Drawings. The Bidders shall be deemed to have gone through the various conditions including sub-soil water conditions, topography of the land, drainage and accessibility etc. or any other condition which in the opinion of contractor will affect his price/rates before quoting their rates. No claim whatsoever against the foregoing shall be entertained.

The drawings with the tender documents are Tender Drawing and are indicative only.

ADDENDA/ CORRIGENDA

Addenda/Corrigenda to the tender documents may be issued prior to the date of submission of the tender to clarify or effect modification in specification and/or contract terms included in various tender documents. The Bidder shall suitably take into consideration such Addenda/Corrigenda while submitting his tender. The Bidder shall return such Addenda/ Corrigenda duly signed and stamped as confirmation of its receipt & acceptance and submit along with the tender document. All addenda/ Corrigenda shall be signed and stamped on each page by the Bidder and shall become part of the tender and contract documents.

SITE VISIT AND COLLECTING LOCAL INFORMATION

Before tendering, the Bidders are advised to visit the site, its surroundings to assess and satisfy themselves about the local conditions such as the working and other constraints at site, approach roads to the site, availability of water & power supply, application of taxes, duties and levies as applicable & any other relevant information required by them to execute complete scope of work. The Bidder may obtain all necessary information as to risks, weather conditions, contingencies & other circumstances (insurgencies etc.) which may influence or affect their tender prices. Bidder shall be deemed to have considered site conditions whether he has inspected it or not and to have satisfied himself in all respect before quoting his rates and no claim or extra charges whatsoever in this regard shall be entertained / payable by the BSCDCL at a later date.

ACCESS BY ROAD

Contractor, if necessary, shall build temporary access roads to the actual site of construction for the works at his own cost to make the site accessible. The Contractor shall maintain the same in motorable condition at all the times as directed by Engineer-in-Charge at his own cost. The contractor shall be required to permit the use of any roads so constructed by him for vehicles of BSCDCL or any other agencies/ contractors who may be engaged on the project site, free of cost.

Non-availability of access roads or approach to site, for the use of the contractor shall in no case condone any delay in the execution of work nor be the cause for any claim for compensation.

HANDING OVER & CLEARING OF SITE

The Contractor should note that area for construction may be made available in phases as per availability and in conjunction with pace of actual progress of work at site. The work may be required to be carried out in constrained situations. The work is to be carried out in such a way that the traffic, people movement, if any, is kept operative and nothing extra shall be payable to the contractor due to this phasing / sequencing of the work. The contractor is required to arrange the resources to complete the entire project within total stipulated time. Traffic diversion, if required, is to be done and maintained as per requirement of local traffic police or/and as per specification, by the contractor at his own cost and the contractor shall not be entitled for any extra payment, whatsoever, in this regard.

The efforts will be made by the BSCDCL to handover the site to the Contractor free of encumbrances. However, in case of any delay in handing over of the site to the Contractor, the BSCDCL shall only consider suitable extension of time for the execution of the work. It should be clearly understood that the BSCDCL shall not consider any revision in contract price or any other compensation whatsoever viz. towards idleness of Contractors labor, equipment etc.

Old structures on the proposed site, if required, shall be demolished by the contractor properly at his own cost unless and otherwise mentioned elsewhere in the tender document. The useful material obtained from demolition of structures & services shall be the property of the owner/BSCDCL and these materials shall be stacked in workmanship like at the place specified by the Engineer-in-charge.

Necessary arrangement including its maintenance is to be made by the contractor for temporary diversion of flow of existing drain and road, as the case may be. The existing drain, road would be demolished, wherever required, with the progress of work under the scope of proposed project. The existing Road and Drain which are not in the alignment of the said project but are affected and/ or

need to demolished during execution for smooth progress of the project, shall be rehabilitated to its original status and condition (including black topping) by the contractor at his own cost. The cost to be incurred by contractor in this regards shall be deemed to be included in the quoted rates of the bill of quantity items and contractor shall not be entitled for any extra payment whatsoever in this regard.

The information about the public utilities (whether over ground or underground) like electrical/ telephone/ water supply lines, OFC Cables, open drain etc. is the responsibility of contractor to ascertain the utilities that are to be affected by the works through the site investigation.

The contractor shall be responsible to obtain necessary approval from the respective authorities for shifting/ re-alignment of existing public utilities. BSCDCL shall only assist the contractor for liasioning in obtaining the approval from the concerned authorities.

Any services affected by the works must be temporarily supported by the contractor who must also take all measures reasonably required by the various bodies to protect their services and property during the progress of works. It shall be deemed to be the part of the contract and no extra payment shall be made to the contractor for the same.

APPROVAL OF TEMPORARY / ENABLING WORKS

The setting and nature of all offices, huts, access road to the work areas and all other temporary works as may be required for the proper execution of the works shall be subject to the approval of the Engineer-in-charge. All the equipments, labour, material including cement, reinforcement and the structural steel required for the enabling/ temporary works associated with the entire Contract-shall have to be arranged by the Contractor only. Nothing extra shall be paid to the Contractor on this account.

CLARIFICATION AFTER TENDER SUBMISSION

Bidder's attention is drawn to the fact that during the period, the tenders are under consideration, the Bidders are advised to refrain from contacting by any means, the BSCDCL and/or his employees/ representatives on matters related to the tender under consideration and that if necessary, BSCDCL will obtain clarifications in writing or as may be necessary. The tender evaluation and process of award of works is done by duly authorized Tender Scrutiny Committee and this committee is authorized to discuss and get clarification from the Bidders.

ORDER OF PRECEDENCE OF DOCUMENTS

In case of difference, contradiction, discrepancy, with regard to conditions of contract, Specifications, Drawings, Bill of quantities etc. forming part of the contract, the following shall prevail in order of precedence.

Letter of Award, along with statement of agreed variations and its enclosures, if any. description of Bill of Quantity / Schedule of Quantities. Special Condition of Contract. Technical specifications (General, Additional and Technical Specification) as given in Tender documents.

General Conditions of Contract. Drawings, CPWD/ BSCDCL specifications (as specified in Technical Specification of the Tender) update with correction slips issued up to last date of receipt of tenders. Relevant B.I.S. Codes.

SECTION-3

CLAUSES OF CONTRACT

CLAUSES OF CONTRACT(CC)

DEFINITIONS

The Contract means the documents forming the tender and acceptance thereof and the formal agreement executed between the competent authority on behalf of BSCDCL and the contractor, together with the documents referred to therein including these conditions, the specifications, Designs, Drawings and instructions issued from time to time by the Engineer-in- Charge and all these documents taken together, shall be deemed to form one contract and shall be complementary to one another.

Bhopal Smart City Development Corporation Limited, hereinafter called 'BSCDCL' propose to get the works executed as mentioned in the Contract on behalf of Owner/ Client as Implementing agency/Executing Agency.

3.1 In the contract, the following expressions shall, unless the context otherwise requires, have the meanings, hereby respectively assigned to them:-

APPROVAL means approved in writing including subsequent written confirmation of previous verbal approval.

BILL OF QUANTITIES or SCHEDULE OF QUANTITIES means the priced and completed Bill of Quantities or Schedule of Quantities forming part of the tender.

CONTRACTOR shall mean the individual, firm, LLP or company, whether incorporated or not, undertaking the works and shall include the legal personal representative of such individual or the persons composing such firm or LLP or company, or the successors of such firm or company and the permitted assignees of such individual, firm or company.

CONTRACT VALUE means the sum for which the tender is accepted as per the letter of Award.

DRAWINGS mean the drawings referred to in the contract document including modifications if any and such other drawings as may from time to time be furnished and/ or approved by BSCDCL.

DATE OF COMMENCEMENT OF WORK: The date of start of contract shall be reckoned from 10 days after the date of issue of letter of Award.

ENGINEER-IN-CHARGE means the Engineer of BSCDCL who shall supervise and be in-charge of the work.

LANGUAGE: All documents and correspondence in respect of this contract shall be in English Language.

“LETTER OF AWARD” shall mean BSCDCL’s letter or notification conveying its acceptance of the tender subject to such conditions as may have been stated therein.

MONTH means English Calendar month „Day“ means a Calendar day of 24 Hrs each.

BSCDCL shall means Bhopal Smart City Development Corporation Limited, a company registered under the Indian Company Act, with its registered office at Near Natraj Petrol Pump, Sector A, Berkheda, Bhopal, Madhya Pradesh 462023 or its Administrative officers or its engineer or other employees authorized to deal with any matter with which these persons are concerned on its behalf.

OWNER/ CLIENT means the Government, Organization, Ministry, Department, Society,

Cooperative, JV Entities (whether incorporated or unincorporated or registered as the case may be) etc. who has awarded the work/ project to BSCDCL and/ or appointed BSCDCL as Implementing / Executing Agency/ Project Manager and/ or for whom BSCDCL is acting as an agent and on whose behalf BSCDCL is entering into the contract and getting the work executed.

SCHEDULE(s) referred to in these conditions shall mean the standard schedule of rates of the government mentioned in the Memorandum (Annexure-I) with the amendments thereto issued up to the date of receipt of the tender.

ii) **SITE** means the lands and other places on, under, in or through Which the works are to be executed or carried out and any other lands or places provided by BSCDCL/client/owner or used for the purpose of thecontract.

iii) **TENDER** means the Contractor's priced offer to BSCDCL for the execution and completion of the work and the remedying of any defects therein in accordance with the provisions of the Contract, as accepted by the Letter of Award or Award letter. The word TENDER is synonymous with Tender and the Word TENDER DOCUMENTS with "Tendering Documents" or "offer documents".

WRITING means any manuscript typed written or printed statement under or over signature and/or seal as the case maybe.

Works or Work shall unless there be something either in the subject or context repugnant to such construction, be construed and taken to mean the works by or by virtue of the contract contracted to be executed whether temporary or permanent, and whether original, altered, substituted or additional.

The headings in the clauses/ conditions of tender documents are for convenience only and shall not be used for interpretation of the clause/ condition.

Words imparting the singular meaning only also include the plurals and vice versa where the context requires. Words importing persons or parties shall include firms and corporations and organizations having legal capacities.

Excepted Risk are risks due to riots (other than those on account of contractor's employees), war (whether declared or not) invasion, act of foreign enemies, hostilities, civil war, rebellion revolution, insurrection, military or usurped power, any acts of Government, damages from aircraft, acts of God, such as earthquake, lightening and unprecedented floods, and other causes over which the contractor has no control and accepted as such by the BSCDCL or causes solely due to use or occupation by Government of the part of the works in respect of which a certificate of completion has been issued or a cause solely due to BSCDCL's faulty design ofworks.

Market Rate shall be the rate as decided by the Engineer-in-Charge of BSCDCL on the basis of the prevailing cost of materials and labour at the site where the work is to be executed plus the percentage mentioned elsewhere in the tender document to cover, all overheads and profits.

PERFORMANCE GUARANTEE:

“Within 30 (Thirty) days from the date of issue of letter of Award or within such extended time as may be granted by BSCDCL in writing, the contractor shall submit to BSCDCL an irrevocable performance bank guarantee in the form appended, from any Nationalized Bank or all Commercial schedule bank equivalent to 10 % (Five per cent only) of the contract value for the due and proper execution of the Contract. The Performance Guarantee shall be initially valid up to the stipulated date of completion plus 60 days beyond that. In case the time for completion of works gets extended, the contractor shall get the validity of Performance Guarantee extended to cover such extended time for completion of work.

BSCDCL reserve the right of forfeiture of the performance guarantee in the event of the contractor’s failure to fulfill any of the contractual obligations or in the event of termination of contract as per terms and conditions of contract.

Performance guarantee shall be returned after completion of 5 years.

In case the contractor fails to submit the performance guarantee of the requisite amount within the stipulated period or extended period, letter of Award automatically will stand withdrawn and EMD of the contractor shall be forfeited.

SECURITY DEPOSIT/ RETENTION MONEY

The Security deposit or the retention money shall be not deducted.

The release/refund of PERFORMANCE GUARANTEE of the contractor shall be subject to the observance/compliance of the conditions as under and whichever is later:

a) Expiry of the defect liability period in conformity with provisions contained in clause (Defect liability clause). The expiry of defect liability period shall be extended from time to time depending upon extension of time granted by BSCDCL.

The contractor produces a clearance certificate from the labour office. As soon as the work is virtually completed, the contractor shall apply for the labour clearance certificate to the Labour Officer under intimation to the Engineer-in-Charge. The Engineer-in-Charge, on receipt of the said communication, shall write to the Labour Officer to intimate if any complaint is pending against the contractor in respect of the work. If no complaint is pending, on record till after 3 months after completion of the work and/or no communication is received from the Labour Officer to this effect till six months after the date of completion, it will be deemed to have received the clearance certificate.

BSCDCL reserves the right of part or full forfeiture of Performance Guarantee in addition to other claims in the event of contractor’s failure to fulfill any of the contractual obligations or in the event of termination of contract as per terms and conditions of contract.

MOBILIZATION ADVANCE

Mobilization advance up to maximum of amount as mentioned in the “Memorandum (Annexure-I)” shall be paid to the contractor, if requested by him, on submission of irrevocable Bank Guarantee valid for contract period of an amount 1.2 times of the mobilization advance to take care of advance and interest at prescribed rate from a

nationalized bank or all Commercial scheduled bank in the enclosed Performa. The Mobilization advance shall be interest bearing @ as mentioned in the “Memorandum (Annexure-I)”.

This advance shall be paid in three installments as follows:

First Installment of fifty percent of total mobilization advance shall be paid after the agreement is signed and upon submission of performance guarantee for full amount as specified.

2nd installment of twenty five percent of total mobilization advance will be paid after the setting up of site office and site laboratory, complete mobilization of plant and machinery, scaffolding & shuttering materials etc.

The Balance twenty five percent of total mobilization advance shall be paid on completion of 10% of work in terms of cost and after the contractor has fully mobilized the work at site.

The mobilization advance bear simple interest at the rate as mentioned in the Memorandum (Annexure-I) and shall be calculated from the date of payment to the date of recovery (365 days in a year) both days inclusive, on the outstanding amount of advance. Recovery of such mobilization advanced including interest shall be made by the deduction from the contractor’s bills commencing after first ten percent of the gross value of the work is executed and paid, on pro-rata percentage basis to the gross value of the work billed beyond 10% in such a way that the entire advance is recovered either by the time eighty percent of the gross value of the contract is executed and paid, together with interest due on the entire outstanding amount up to the date of recovery of the installment or on expiry of eighty percent of contract period (i.e. time allowed for completion of work in terms of Memorandum- Annexure-I) whichever is earlier.

The bank guarantee submitted by contractor against mobilization advance shall initially be made for the full amount and valid for the contract period, and be kept renewed from time to time to cover the balance amount and likely period of completion of recovery together with interest. However, the contractor can submit part bank guarantees against the mobilization advance in as many numbers as per proposed number of recovery installments equivalent to the amount of each installment.

Not with standing what is contained above, no mobilization advance whatsoever shall be payable, if payment of mobilization advance is not mentioned in the Memorandum (Annexure-I).

SECURED ADVANCE AGAINST NON-PERISHABLE MATERIALS

Interest free secured advance up-to a maximum of 75 % (seventy five percent) of the Market Value of the Materials or the 75 % (seventy five percent) cost of materials as derived from the tendered item rate of the contractor, whichever is less, required for incorporation in the permanent works and brought to site and duly certified by BSCDCL site Engineer shall be paid to the Contractor for all non- perishable items as per UADD/MPPWD/CPWD norms. The advance will be paid only on submission of Indemnity Bond in the prescribed pro-forma. The advance shall be recovered in full from next Running Account bill and fresh advance shall be paid for the balance quantities of materials. The contractor shall construct suitable go-down at the site of work for safe storage of the materials against any possible damages due to sun, rain, dampness, fire, theft etc. at his own cost. He shall also employ necessary watch & ward establishment for the purpose at his costs and risks.

Such secured advance shall also be payable on other items of perishable nature, fragile and combustible with the approval of the Engineer-in-Charge provided the contractor provides a comprehensive insurance cover for the full cost of such materials. The decision of the Engineer-in-Charge shall be final and binding on the contractor in this matter. No secured advance shall however, be paid on high risk materials such as ordinary glass, sand, petrol, diesel etc.

DEVIATIONS / VARIATIONS EXTENT AND PRICING

The Engineer-in-Charge shall have power (i) to make any alterations in, omissions from, additions to or substitutions for, the original specifications, drawings, designs and instructions that may appear to him to be necessary during the progress of the work, (ii) to omit part of the works in case of non-availability of a portion of the site or for any other reasons and the contractor shall be bound to carry out the works in accordance with any instructions given to him in writing signed by the Engineer-in-Charge and such alterations, omissions, additions, or substitutions shall form part of the contract as if originally provided therein and any altered, additions or substituted works which the contractor may be directed to do in the manner specified above as part of the work, shall be carried out by the contractor on the same conditions in all respects including price on which he agreed to do the main work except as here under provided:

The time for the completion of the work shall, in the event of any deviations resulting in additional cost over the tendered value sum being ordered be extended, if requested by the contractor, as follows: in the proportion which the additional cost of the altered, additional or substituted work bears to the original tendered value plus 25% of the time calculated in (i) above or such further additional time as may be considered reasonable by the Engineer-in-Charge.

If the extra items includes any work for which no rate is specified in the contract, then such work shall be carried out at the rates entered in the schedule of rates (as mentioned in Memorandum (Annexure-I)) for Civil Works minus/plus the percentage which the tendered amount of scheduled items bears with the estimated amount of schedule items based on the Schedule of Rates (as mentioned in Memorandum (Annexure-I) for Civil Works). The scheduled item means the items appearing in the Schedule of Rates (as mentioned in Memorandum (Annexure-I) for Civil) which shall be applicable in this clause. This clause will apply mutates mutandis to electrical work except that Electrical Schedule of Rates as mentioned in Memorandum (Annexure-I) will be considered in place of Civil works Schedule of rates as mentioned in Memorandum (Annexure-I)

However, In the case of extra item(s), (items that are completely new, and are in addition to the items contained in the contract, and not included in the schedule of rates (as mentioned in Memorandum (Annexure-I)), the contractor may within fifteen days of receipt of order or occurrence of the item(s) claim rates, supported by proper analysis, for the work and the engineer-in-charge shall within one month of the receipt of the claims supported by analysis, after giving consideration to the analysis of the rates submitted by the contractor, determine the rates on the basis of the market rates and the contractor shall be paid in accordance with the rates so determined.

In the case of substituted items (items that are taken up with partial substitution or in lieu of items of work in the contract), the rate for the agreement item (to be substituted) and substituted item shall also be determined in the manner as mentioned in the following para:

If the market rate for the substituted item so determined is more than the market rate of agreement item (to be substituted), the rate payable to the contractor for the substituted

item shall be the rate for the agreement item (to be substituted) so increased to the extent of the difference between the market rates of substituted item and the agreement item (to be substituted).

If the market rate for the substituted item so determined is less than the market rate of the agreement (to be substituted), the rate payable to the contractor for the substituted item shall be the rate for the agreement item (to be substituted) so decreased to the extent of the difference between the market rates of substituted item and the agreement item (to be substituted)

In the case of contract item(s), substituted item(s), contract cum substituted items, which exceed the limits laid down in Memorandum (Annexure-I), the contractor shall within fifteen days of receipt of order of occurrence of the excess, claim revision of the rates, supported by proper analysis for the work in excess of the above mentioned limits, provided that if the rates so claimed are in excess of the rates specified in the scheduled of quantities, the Engineer-in-Charge shall within one month of receipt of the claims supported by analysis, after giving consideration to the analysis of the rates submitted by the Contractor, determine the rates on the basis of the market rates and the contractor shall be paid in accordance with the rates so determined.

The provisions of the preceding paragraph shall also apply to the decrease in the rates of items for the work in excess of the limits laid down in Memorandum (Annexure-I), and the Engineer-in-charge shall after giving notice of the contractor within one month of occurrence of the excess and after taking into consideration any reply received from him within fifteen days of the receipt of the notice revise the rates for the work in question within one month of the expiry of the said period of fifteen days having regard to the market rates.

3.2 The contractor shall send to the Engineer-in-Charge once every three months, an up to date account giving complete details of all claims for additional payments to which the contractor may consider himself entitled and of all additional work ordered by the Engineer- in-Charge which he has executed during the preceding quarter failing which the contractor shall be deemed to have waived his right. However, the Engineer-in-charge may authorize consideration of such claims on merits.

For the purpose of operation of Memorandum (Annexure-I), the following works shall be treated as works relating to foundation unless and otherwise defined in the Contract:

Any operation incidental to or necessarily has to be in contemplation of Bidder while filling, tender or necessary for proper execution of the item included in the Schedule of quantities or in the schedule of rates mentioned above, whether or not specifically indicated in the description of the item and the relevant specifications shall be deemed to be included in the rates quoted by the Bidder or the rate given in the said schedule or rates as the case may be Nothing extra shall be admissible for such operations.

Market Rates to be determined as per clauses given in the tender document shall be on the basis of **Prevailing rates of Material (unless mentioned otherwise), Relevant Labour authority rate for Labour, market rates of T&P etc. plus 15% towards Contractors's Profits and Overheads.**

The following factors may be considered in the justification of rates on which

Contractor's overhead & profit shall not be applicable:

Buildings and Other Construction Worker Cess as applicable in the state of work place
EPF (Employer Contribution) component, as per EPF act on the portion of labour's
wages

ESCALATION

No claim on account of any escalation on whatsoever ground shall be entertained at any stage of works. All rates as per Bill of Quantities (BOQ) quoted by contractor shall be firm and fixed for entire contract period as well as extended period for completion of the works. No escalation shall be applicable on this contract. Escalation shall considered for only Fuel Cost of moving Vehicles.

COMPENSATION FOR DELAY

If the contractor fails to maintain the required progress in terms of clause or relevant clause of GCC & Special Conditions of Contract, to complete the work and clear the site on or before the contract or extended date of completion, he shall, without prejudice to any other right or remedy available under the law to the BSCDCL on account of such breach, pay as agreed compensation the amount calculated at the rates stipulated below as the Engineer in charge (whose decision in writing shall be final and binding) may decide on the amount of tendered value of the work for every completed day / week (as applicable) that the progress remains below that specified in Clause or the relevant clause in GCC & Special Conditions of Contract or that the work remains incomplete.

This will also apply to items or group of items for which a separate period of completion has been specified

- i) Compensation for delay of work @1.5% per month delay to be computed on daily basis.

Provided always that the total amount of compensation for delay to be paid under this Condition shall not exceed 10% of the Tendered Value of work or of the Tendered Value of the item or group of items of work for which a separate period of completion is originally given. The amount of compensation may be adjusted or set-off against any sum payable to the Contractor under this or any other contract with BSCDCL.

In case, the contractor does not achieve a particular milestone mentioned elsewhere in the tender document, or the re-scheduled milestone(s) the amount shown against that milestone shall be withheld, to be adjusted against the compensation levied at the final grant of Extension of Time. With-holding of this amount or failure to achieve a milestone, shall be automatic without any notice to the Contractor. However, if the contractor catches up with the progress of work on the subsequent milestone(s), the withheld amount shall be released. In case the contractor fails to make up for the delay in subsequent milestone(s), amount mentioned against each milestone missed subsequently also shall be withheld. However, no interest, whatsoever, shall be payable on such with held amount.

ACTION IN CASE WORK NOT DONE AS PER SPECIFICATIONS

All works under or in course of execution or executed in pursuance of the contract, shall at all times be open and accessible to the inspection and supervision of the Engineer-in-charge, his authorized subordinates in charge of the work and all the superior officers, officer of the Quality Assurance Unit of the BSCDCL or any organization engaged by

the BSCDCL for Quality Assurance and the contractor shall, at all times, during the usual working hours and at all other times at which reasonable notice of the visit of such officers has been given to the contractor, either himself be present to receive orders and instructions or have a responsible agent duly accredited in writing, present for that purpose. Orders given to the Contractor's agent shall be considered to have the same force as if they had been given to the contractor himself. If it shall appear to the Engineer-in-charge or his authorized subordinates in-charge of the work or to the officer of Quality Assurance or his subordinate officers or the officers of the organization engaged by the BSCDCL for Quality Assurance or his subordinate officers, that any work has been executed with unsound, imperfect, or unskillful workmanship, or with materials or articles provided by him for the execution of the work which are unsound or of a quality inferior to that contracted or otherwise not in accordance with the contract, the contractor shall, on demand in writing which shall be made within twelve months of the completion of the work from the Engineer-in-Charge specifying the work, materials or articles complained of notwithstanding that the same may have been passed, certified and paid for forthwith rectify, or remove and reconstruct the work so specified in whole or in part, as the case may require or as the case may be, remove the materials or articles so specified and provide other proper and suitable materials or articles at his own charge and cost. In the event of the failing to do so within a period specified by the Engineer-in-Charge in his demand aforesaid, then the contractor shall be liable to pay compensation at the same rate as given in this tender document (for non-completion of the work in time) for this default. In such case the Engineer-in-Charge may not accept the item of work at the rates applicable under the contract but may accept such items at reduced rates as the Engineer in charge may consider reasonable during the preparation of on account bills or final bill if the item is so acceptable without detriment to the safety and utility of the item and the structure or he may reject the work outright without any payment and/or get it and other connected and incidental items rectified, or removed and re-executed at the risk and cost of the contractor. Decision of the Engineer-in-Charge to be conveyed in writing in respect of the same will be final and binding on the contractor.

ACTION IN CASE OF BAD WORK

If it shall appear to the Engineer-in-Charge or his authorized representative in charge of the work or to the Chief Technical Examiner or to any other inspecting agency of Government/ State Government/ Owner where the work is being executed, that any work has been executed with unsound, imperfect, or unskillful workmanship or with materials of any inferior description, or that any materials or articles provided by him for the execution of the work are unsound or of a quality inferior to that contracted for or otherwise not in accordance with the contract, the contractor shall on demand in writing which shall be made within twelve months of the completion of the work from the Engineer-in-Charge specifying the work, materials or articles complained of notwithstanding that the same may have been passed, Certified and paid for forthwith rectify, or remove and reconstruct the work so specified in whole or in part as the case may require or as the case may be, remove the materials or articles so specified and provide other proper and suitable materials or articles at his own proper charge and cost, and in the event of his failing to do so within a period to be specified by the Engineer-in-Charge in his demand aforesaid while the contractor failure to do so shall continue, the Engineer-in-Charge may rectify or remove and re-execute the work or remove and replace with others, the material or articles complained of as the case may be at the risk and expense in all respects of the contractor.

CANCELLATION/DETERMINATION OF CONTRACT IN FULL OR PART

Subject to other provisions contained in this clause the Engineer-in-Charge may, without prejudice to his any other rights or remedy against the contractor in respect of any delay, inferior workmanship, any claims for damages and / or any other provisions of this contract or otherwise, and whether the date of completion has or has not elapsed, by notice in writing absolutely determine the contract in any of the following cases:

If the contractor having been given by the Engineer-in-Charge a notice in writing to rectify, reconstruct or replace any defective work or that the work is being performed in an inefficient or otherwise improper or un-workmanlike manner shall omit to comply with the requirement of such notice for a period of seven days thereafter; or

If the contractor has, without reasonable cause, suspended the progress of the work or has failed to proceed with the work with due diligence so that in the opinion of the Engineer-in-Charge (which shall be final and binding) he will be unable to secure completion of the work by the date for completion and continues to do so after a notice in writing of seven days from the Engineer-in-Charge; or

If the contractor fails to complete the work within the stipulated date or items of work with individual date of completion, if any stipulated, on or before such date(s) of completion and does not complete them within the period specified in a notice given in writing in that behalf by the Engineer-in-Charge; or

If the contractor persistently neglects to carry out his obligations under the contract and / or commits default in complying with any of the terms and conditions of the contract and does not remedy it or take effective steps to remedy it within 7 days after a notice in writing is given to him in that behalf by the Engineer-in-Charge; or

If the contractor shall offer or give or agree to give to any person in BSCDCL service or to any other person on his behalf any gift or consideration of any kind as an inducement or reward for doing or forbearing to do or for having done or forborne to do any action relation to the obtaining or execution of this or any other contract for BSCDCL; or If the contractor shall enter into a contract with BSCDCL in connection with which commission has been paid or agreed to be paid by him or to his knowledge, unless the particulars of any such commission and the terms of payment thereof have been previously disclosed in writing to the Engineer-in-Charge; or

If the contractor shall obtain a contract with BSCDCL as a result of wrong tendering or other non-bona-fide methods of competitive tendering or commits breach of Integrity Pact; or If the contractor being an individual, or if a firm, any partner thereof shall at any time be adjudged insolvent or have a receiving order or order for administration of his estate made against him or shall take any proceedings for liquidation or composition (other than a voluntary liquidation for the purpose of amalgamation or reconstruction) under any Insolvency Act for the time being in force or make any conveyance or assignment of his effects or composition or arrangement for the benefit of his creditors or purport so to do, or if any application be made under any Insolvency Act for the time being in force for the sequestration of his estate or if a trust deed be executed by him for benefit of his creditors; or If the contractor being a company, shall pass a resolution or the Court shall make an order for the winding up of the company, or a receiver or manager on behalf of the debenture holders or otherwise shall be appointed or circumstances shall arise which entitle the Court or debenture holders to appoint a receiver or manager; or If the contractor shall suffer an execution being levied on his goods and allow it to be continued for a period of 21 days, or.

If the contractor assigns, transfers, sublets (engagement of labour on a piece-work basis or of the labour with materials not to be incorporated in the work, shall not be deemed

to be subletting) or otherwise parts with or attempts to assign, transfer sublet or otherwise parts with the entire works or any portion thereof without and prior written approval of the Engineer-in-Charge.

When the contractor has made himself liable for action under any of the cases aforesaid, the Engineer-in-Charge may without prejudice to any other right or remedy which shall have accrued or shall accrue hereafter to BSCDCL, by a notice in writing to cancel the contract as whole or only such items of work in default from the Contract, the Engineer-in-charge shall have powers:

Take possession of site and any materials, constructional plant, implements, stores, etc. thereon; and/ or

Carry out the incomplete work by any means at the risk and cost of the contractor; and/ or

The Engineer-in-charge shall determine the amount, if any, is recoverable from the contractor for completion of the part work/part in complete work of any item(s) taken out of his hands and execute at the risk and cost of the contractor, the liability of contractor on account of loss or damage suffered by BSCDCL because of action under this clause shall not exceed 10% of the tendered value of the work.

To determine or rescind the contract as aforesaid (of which termination or rescission notice in writing to the contractor under the hand of the Engineer-in-Charge shall be conclusive evidence). Upon such determination or rescission the full performance guarantee shall be liable to be forfeited and un-used materials, construction plants, implements, temporary buildings, etc. shall be taken over and shall be absolutely at the disposal of the BSCDCL. and/ or

To employ labor paid by the BSCDCL and to supply materials to carry out the work or any part of the work debiting the contractor with the cost of the labour and the price of the materials of the amount of which cost and price certified by the Engineer-in-Charge shall be final and conclusive) against the contractor and crediting him with the value of the work done in all respects in the same manner and at the same rates as if it had been carried out by the contractor under the terms of his contract. The certificate of the Engineer-in-Charge as to the value of the work done shall be final and conclusive against the contractor provided always that action under the sub-clause shall only be taken after giving notice in writing to the contractor. If the expenses incurred by the BSCDCL are less than the amount payable to the contractor at his agreement rates, the difference shall not be paid to the contractor; and/ or

After giving notice to the contractor to measure up the work of the contractor and to take such whole, or the balance or part thereof as shall be un-executed or delayed with reference to the General Conditions of Contract and/ or relevant clause of Condition Special of Contract, out of his hands and to give it to another contractor to complete in which case any expenses which may be incurred in excess of the sum which would have been paid to the original contractor if the whole work had been executed by him (of the amount of which excess the certificate in writing of the Engineer-in-Charge shall be final and conclusive) shall be borne and paid by the original contractor and may be deducted from any money due to him by BSCDCL under his contract

or the proceeds of sales of unused materials, construction plants, implements temporary buildings etc. thereof or a sufficient part thereof as the case may be. If the expenses incurred by the BSCDCL are less than the amount payable to the contractor at his agreement rates, the difference shall not be paid to the contractor; and/or By a notice in writing to withdraw from the contractor any items or items of work as the Engineer-in-charge may determine in his

absolute discretion and get the same executed at the risk and cost of the contractor.

Any excess expenditure incurred or to be incurred by BSCDCL in completing the works or part of the works or the excess loss or damages suffered or may be suffered by BSCDCL as aforesaid after allowing such credit shall without prejudice to any other right or remedy available to BSCDCL in law be recovered from any moneys due to the contractor on any account, and if such moneys are not sufficient the contractor shall be called upon in writing and shall be liable to pay the same within 30days.

If the contractor shall fail to pay the required sum within the aforesaid period of 30 days, the Engineer-in-Charge shall have the right to sell any or all of the contractors unused materials, constructional plant, implements, temporary buildings, etc. and apply the proceeds of sale thereof towards the satisfaction of any sums due from the contractor under the contract and if thereafter there be any balance outstanding from the contractor, it shall be recovered in accordance with the provisions of the contract and law.

Any sums in excess of the amounts due to BSCDCL and unsold materials, constructional plant etc. shall be returned to the contractor, provided always that if cost or anticipated cost of completion by BSCDCL of the works or part of the works is less than the amount which the contractor would have been paid had he completed the works or part of the works, such benefit shall not accrue to the contractor.

In the event of anyone or more of the above courses being adopted by the Engineer-in-Charge the contractor shall have no claim to compensation for any loss sustained by him by reasons of his having purchased or procured any materials or entered into any engagements or made any advances on account or with a view to the execution of the work or the performance of the contract. And in case action is taken under any of the provision aforesaid the contractor shall not be entitled to recover or be paid any sum for any work thereof or actually performed under this contract unless and until the Engineer-in-Charge has certified in writing the performance of such work and the value payable in respect thereof and he shall only be entitled to be paid the value so certified. Provided further that if any of the recoveries to be made, while taking action as above, are in excess of the performance guarantee forfeited.

CONTRACTOR LIABLE TO PAY COMPENSATION EVEN IF ACTION NOT TAKEN UNDER CLAUSE OF AGREEMENT

In any case in which any of the powers conferred upon the Engineer-in-Charge by relevant clause thereof, shall have become exercisable and the same are not exercised, the non-exercise thereof shall not constitute a waiver of any of the conditions hereof and such powers shall notwithstanding be exercisable in the event of any future case of default by the contractor and the liability of the contractor for compensation shall remain unaffected. In the event of the Engineer-in-Charge putting in force all or any of the powers vested in him under any clause he may, if he so desires after giving a notice in writing to the contractor, take possession of (or at the sole discretion of the Engineer-in-Charge which shall be final and binding on the contractor) use as on hire (the amount of the hire money being also in the final determination of the Engineer-in-Charge) all or any tools, plant, materials and stores, in or upon the works, or the site thereof belonging to the contractor, or procured by the contractor and intended to be used for the execution of the work/or any part thereof, paying or allowing for the same in account at the contract rates, or in the case of these not being applicable, at current market rates to be certified by the Engineer-in-Charge, whose certificate thereof shall be final and binding on the contractor and/or direct the contractor, clerk of the works, foreman or other authorized agent to remove such tools, plant, materials, or stores from the premises (within a time to be specified in such notice) in the event of the contractor failing to comply with any such requisition, the Engineer-in-Charge may remove them at the contractor's expense or sell them by auction or private

sale on account of the contractor and his risk in all respects and the certificate of the Engineer-in-Charge as to the expenses of any such removal and the amount of the proceeds and expenses of any such sale shall be final and conclusive against the contractor.

CARRYING OUT PART WORK AT RISK & COST OF CONTRACTOR

If contractor:

At any time makes default during currency of work or does not execute any part of the work with due diligence and continues to do so even after a notice in writing of 7 days in this respect from the Engineer-in-Charge;or

Commits default in complying with any of the terms and conditions of the contract and does not remedy it or takes effective steps to remedy it within 7 days even after a notice in writing is given in that behalf by the Engineer-in- Charge;or

Fails to complete the work(s) or items of work with individual dates of completion, on or before the date(s) so determined, and does not complete them within the period specified in the notice given in writing in that behalf by the Engineer-in-Charge.

The Engineer-in-Charge without invoking action under given clause of contract may, without prejudice to any other right or remedy against the contractor which have either accrued or accrue thereafter to BSCDCL, by a notice in writing to take the part work/part incomplete work of any item(s) out of his hands and shall have powers to: Take possession of the site and any materials, constructional plant, implements, stores, etc., thereon; and/or Carry out the part work / part incomplete work of any item(s) by any means at the risk and cost of the contractor.

The Engineer-in-Charge shall determine the amount, if any, is recoverable from the contractor for completion of the part work/ part incomplete work of any item(s) taken out of his hands and execute at the risk and cost of the contractor, the liability of contractor on account of loss or damage suffered by BSCDCL because of action under this clause shall not exceed 10% of the tendered value of thework.

In determining the amount, credit shall be given to the contractor with the value of work done in all respect in the same manner and at the same rate as if it had been carried out by the original contractor under the terms of his contract, the value of contractor's materials taken over and incorporated in the work and use of plant and machinery belonging to the contractor. The certificate of the Engineer-in-Charge as to the value of work done shall be final and conclusive against the contractor provided always that action under this clause shall only be taken after giving notice in writing to the contractor. Provided also that if the expenses incurred by the department are less than the amount payable to the contractor at his agreement rates, the difference shall not be payable to the contractor.

Any excess expenditure incurred or to be incurred by BSCDCL in completing the part work/ part incomplete work of any item(s) or the excess loss of damages suffered or may be suffered by BSCDCL as aforesaid after allowing such credit shall without prejudice to any other right or remedy available to BSCDCL in law or per as agreement be recovered from any money due to the contractor on any account, and if such money is insufficient, the contractor shall be called upon in writing and shall be liable to pay the same within 30days.

If the contractor fails to pay the required sum within the aforesaid period of 30 days, the Engineer-in-Charge shall have the right to sell any or all of the contractors' unused materials, constructional plant, implements, temporary building at site etc. and adjust the proceeds of sale thereof towards the dues recoverable from the contractor under the

contract and if thereafter there remains any balance outstanding, it shall be recovered in accordance with the provisions of the contract. In the event of above course being adopted by the Engineer-in-Charge, the contractor shall have no claim to compensation for any loss sustained by him by reason of his having purchased or procured any materials or entered into any engagements or made any advance on any account or with a view to the execution of the work or the performance of the contract.

SUSPENSION OF WORKS

The contractor shall, on receipt of the order in writing of the Engineer-in-charge, suspend the progress of the works or any part thereof for such time and in such manner as the Engineer-in-charge may consider necessary for any of the following reasons:

- On account of any default on part of the contractor, or
- For proper execution of the works or part thereof for reason other than the default of the contractor, or
- For safety of the works or part thereof.

The contractor shall, during such suspension, properly protect and secure the works to the extent necessary and carry out the instructions given in that behalf by the Engineer-in-charge.

(b) If the suspension is ordered for reasons (ii) and (iii) in sub-para (a) above.

The contractor shall be entitled to an extension of the time equal to the period of every such suspension plus 25% for completion period. No adjustment in contract price will be allowed for reasons of such suspension.

ii) In the event of the Contractor treating the suspension as an abandonment of the Contract by BSCDCL, he shall have no claim to payment of any compensation on account of any profit or advantage which he may have derived from the execution of the work in full.

TERMINATION OF CONTRACT ON DEATH OF CONTRACTOR

Without prejudice to any of the right or remedies under this contract if the contractor dies, the Engineer in-charge shall have the option of terminating the contract without compensation to the contractor.

TIME ESSENCE OF CONTRACT & EXTENSION FOR DELAY

The time allowed for execution of the Works as specified in the Memorandum (Annexure-I) or the extended time in accordance with these conditions shall be the essence of the contract. The execution of the works shall commence from such time period as mentioned in MEMORANDUM (ANNEXURE – I) or the date on which the Engineer-in-Charge issues written orders to commence the work. If the Contractor commits default in commencing the execution of the work as aforesaid, the BSCDCL shall without prejudice to any other right or remedy available in law, be at liberty to forfeit the earnest money & performance guarantee absolutely.

3.3 Within 10 (Ten) days of Letter of Award, the Contractor shall submit a Time and Progress Chart (CPM/ PERT/ Quantified Bar Chart) and get it approved by the Engineer-in-Charge. The Chart shall be prepared in direct relation to the time stated in the contract documents for completion of items of the works. It shall indicate the forecast (mile-stones) of the dates of commencement and completion of various items, trades, sections of the work and may be amended as necessary by agreement between the Engineer-in-Charge and the Contractor within the limitations of time stipulated in the Contract

documents and further to ensure good progress during the execution of the work, the contractor shall in all cases in which the time allowed for any work exceeds one month (save for special jobs for which a separate program has been agreed upon) complete 1/8th of the whole of work before 1/4th of the whole time allowed in the contract has elapsed, 3/8th of the work before one half of such time has elapsed and 3/4th of the work before 3/4th of such time has elapsed. The physical progress report including photographs shall be submitted by the contractor on the prescribed format & the intervals (not exceeding one month) as decided by the Engineer in Charge. The compensation for delay as per tender document shall be leviable at intermediate stages also, in case the required progress is not achieved to meet the above time deadlines of the completion period and/ or milestones of time and progress chart, provided always that the total amount of Compensation for delay to be paid under this condition shall not exceed 10% of the tendered value of work”.

If the work(s) be delayed by:

1. force-majeure or
2. Abnormally bad weather, or
3. Serious loss or damage by fire, or
4. Civil commotion, local commotion of workmen, strike or lockout, affecting any or the trades employed on the work, or
5. Delay on the part of other contractors or tradesmen engaged by Engineer-in- Charge in executing work not forming part of the Contract, or
6. Non-availability of stores, which are responsibility of the BSCDCL or,
7. Non-availability or break down of tools and plant to be supplied or supplied by BSCDCL
or,
8. Any other cause which, in the absolute discretion of the BSCDCL, is beyond the Contractor’s control, then upon the happening of any such event causing delay, the Contractor shall immediately give notice thereof in writing to the Engineer-in- Charge within 07 days but shall nevertheless use constantly his best endeavor to prevent or make good the delay and shall do all that may be reasonably required to the satisfaction of the Engineer-in-Charge to proceed with the works.

3.4 Request for extension of time, to be eligible for consideration, shall be made by the Contractor in writing within fourteen days of the happening of the event causing delay in the prescribed form. The Contractor may also, if practicable, indicate in such a request the period for which extension is desired. In any such case BSCDCL may give a fair and reasonable extension of time for completion of work. Such extension shall be communicated to the Contractor by the Engineer-in-Charge in writing within a reasonable time from the receipt of such request. Non application by the contractor for extension of time shall not be a bar for giving a fair and reasonable extension by the Engineer-in-Charge and the extension of time so given by the Engineer-in-Charge shall be binding on the contractor.

TIME SCHEDULE & PROGRESS

Time allowed for carrying out all the works as entered in the tender shall be as mentioned in the “Memorandum (Annexure-I)” which shall be reckoned from the 10th day from the date on which the letter of Award is issued to the Contractor. Time shall be the essence of the contract and contractor shall ensure the completion of the entire work within the stipulated time of completion.

The contractor shall also furnish within 10 days of date of issue of letter of Award a CPM network/ PERT chart/ Bar Chart for completion of work within stipulated time. This will be duly got approved from BSCDCL. This approved Network/ PERT Chart shall form a part of the agreement. Achievement of milestones as well as total completion has to be within the time period allowed. Contractor shall mobilize and employ sufficient resources for completion of all the works as indicated in the agreed BAR CHART/PERT Network.

No additional payment will be made to the contractor for any multiple shift work or other incentive methods contemplated by him in his work schedule even though the time schedule is approved by the Engineer-in-Charge.

During the currency of the work the contractor is expected to adhere to the time schedule on mile stone and total completion and this adherence will be a part of Contractor's under the contract. During the time schedule on mile stone and total completion and this adherence will be a part of Contractor's performance under the contract. During the execution of the work contractor is expected to participate in the review and updating of the Network/BAR CHART undertaken by the BSCDCL. These reviews may be undertaken at the discretion of Engineer-in-charge either as a periodical appraisal measure or when the quantum of work order on the contractor is substantially changed through deviation orders or amendments. The review shall be held at site or any of the offices of BSCDCL/owner /consultant at the sole discretion of BSCDCL. The contractor will adhere to the revised schedule thereafter. The approval to the revised schedule resulting in a completion date beyond the stipulated date of completion shall not automatically amount to a grant of extension of time to the contractor.

Contractor shall submit (as directed by Engineer-in-Charge) progress reports on a computer based program (program and software to be approved by Engineer-in-Charge) highlighting status of various activities and physical completion of work. The contractor shall send completion report with as built drawings to the office of Engineer-in-Charge, of BSCDCL in writing within a period of 30 days of completion of work.

The photographs of the project taken on last day of every month indicating progress of work (in soft copies) shall be attached along with the physical progress reports to be submitted to Engineer-in-charge.

TAXES AND DUTIES

3.5 Except as otherwise specifically provided in the contract, the contractor shall be liable and responsible for the payment, of all taxes, and GST or in the state concerned which may be specified by local/state/ central government from time to time on all material articles which may be used for this work. The rates quoted by him in the tender in bill of quantities shall be Excluded of GST (i.e. if Applicable GST Shall be paid Separately). In the event of nonpayment/default in payment of any of the above taxes, BSCDCL reserves the right to with-hold the dues/payments of contractor and make payment to local/state/Central Government authorities or to labourers as may be applicable. The rate quoted by the contractor shall be deemed to be Exclusive of GST as given in tender document Tax deductions at source shall be made as per laws prevalent in the State as applicable for the work.

The stamp duty and registration charges, if any, on the contract agreement levied by the Government or any other statutory body, shall be paid by the contractor as applicable in the state of work.

It will be incumbent upon the Contractor to obtain a registration certificate as a dealer under the GST Act and necessary evidence to this effect shall be furnished by the Contractor to BSCDCL.

The Bidder shall quote his rates Exclusive of Goods and Service Tax(GST)in conjunction with other terms and conditions. In the event of decrease / relaxation and / or waiver of any of the existing / prevailing tax(es), duties, levies, cess by Central /state Govt. Or any other statutory body(ies), after the last stipulated date for the receipt of tender including extension (if any), and the contractor thereupon has been paid or has raised claims of such tax(es), duties, levies, cess; such sums shall be recovered / deducted (from claims raised but which has not been paid) effective from the date as reckoned in the relevant statutory order / law / ordinance etc. The contractor, shall, within a period of 30 days of any such waiver/relaxation/decrease in tax(es), duties, levies, cess, give a written notice thereof to Engineer-in-charge stating the statutory change with Documentary proof thereto. Provided always that Engineer-in-charge shall have full powers to effect recovery/deduction on account of any such statutory change even if contractor has not intimated in the event when any such statutory action comes to his notice.

INCOME TAX DEDUCTION (TDS)

Income tax deductions shall be made from all payments made to the contractor including advances against work done, as per the rules and regulations in force, in accordance with the Income Tax act prevailing from time to time.

GOODS AND SERVICES TAX (GST)

The Bidder shall quote rates Exclusive of GST(i.e. If Required GST Shall be paid separately) nothing extra shall be paid. The contractor must have GST registration number and will provide copy of Registration to BSCDCL before release of any payment by the Corporation. The contractor will submit regular Invoice / Bill fulfilling all conditions of Goods and Service Tax (GST)Rules.

ROYALTY ON MATERIALS:

The contractor shall deposit royalty and obtain necessary permit for supply of bajri, stone, kankar, sand and other materials etc. from the local authorities and quoted rates shall be inclusive of royalty.

The contractor shall be deemed to have inspected the site, its surrounding and acquainted itself with the nature of the ground, accessibility of the site and full extent and nature of all operations necessary for the full and proper execution of the contract, space for storage of materials, constructional plant, temporary works, restrictions on the plying of heavy vehicles in area, supply and use of labour materials, plant, equipment and laws, rules and regulations, if any, imposed by the local authorities.

The rates and prices to be tendered in the bill of quantities are for completed and finished items of works and complete in all respects. It will be deemed to include all constructional plant, labour, supervision materials, transport, all temporary works, erection, maintenance, contractor's profit and establishment/overheads, together with preparation of designs & drawings pertaining to casting yard, shop drawing, fabrication drawing (if required), staging form work, stacking yard, etc. all general risk, all taxes, royalty, duties, cess, octroi and other levies, insurance liabilities and obligations set out or implied in the tender documents and contract.

If any temporary/ permanent structure is encountered or safety of such structure in the vicinity is endangered due to execution of the project, the contractor has to protect the

structures by any means as per direction of Engineer-in-Charge. If any damage is caused to any temporary or permanent structure(s) in the vicinity due to execution of the project, the contractor has to make good the same by any means as per direction of Engineer-in-Charge. The contractor should inspect the site of work from this point of view. The cost to be incurred in this regard shall be deemed to be included in his quoted rates of BOQ items and the contractor shall not be entitled for any extra payment in this regard.

INSURANCE OF WORKS ETC

Contractor is required to take contractor's all risk policy or erection all risk policy (as the case may be) from an approved insurance company in the joint name with BSCDCL and bear all costs towards the same for the full period of execution of works including the defect liability period for the full amount of contract against all loss of damage from whatever cause arising other than **excepted risks** for which he is responsible under the terms of the contract and in such manner that the BSCDCL and the contractor are covered during the period of construction of works and/or also covered during the period of defect liability for loss or damage. The work and the temporary works to the full value of such works. The materials, constructional plant, centering, shuttering and scaffolding materials and other things brought to the site for their full value. Whenever required by BSCDCL, the contractor shall produce the policy or the policies of insurance and the receipts for payment of the current premium.

INSURANCE UNDER WORKMEN COMPENSATION ACT

Contractor is required to take insurance cover under the Workman Compensation Act, 1923 amended from time to time from an approved insurance company and pay premium charges thereof. Wherever required by BSCDCL the contractor shall produce the policy or the policies of Insurance and the receipt of payment of the current premiums.

THIRD PARTY INSURANCE

Contractor is required to take third party insurance cover for an amount of 5% (five percent) of contract value from an approved insurance company for insurance against any damage, injury or loss which may occur to any person or property including that of BSCDCL / owner / client, arising out of the execution of the works or temporary works. Wherever required by BSCDCL the contractor shall produce the policy or the policies of Insurance and the receipt of payment of the current premiums.

In case of failure of the contractor to obtain contractor's all risk policy, insurance under workman compensation act and third party insurance as described above within one month from the date of commencement of work, running account payments of the contractor shall be withheld till such time the aforesaid insurance covers are obtained by the contractor.

If the Contractor could not effect a comprehensive insurance cover against risks which he may be required to effect under the terms of the contract, then he shall give his attention to get the best insurance cover available and even in case of effecting a wider insurance cover than the one which the subsidiary of the General Insurance Company could offer, such an insurance is ought to be done after the BSCDCL's approval, by or through the subsidiary of the General Insurance Company.

The contractor shall at all times indemnify BSCDCL and Owner against all claims, damages or compensation under the provision of Payment of wages act-1936, Minimum Wages Act-1948, Employer's liability Act-1938, the workmen's compensation Act-1947, Industrial Disputes Act-1947 and Maternity Benefit Act-1961 or any modifications thereof or any other law in force or as consequence of any accident or injury to any workman or other persons in or about the works, whether in the employment of the contractor or not, against all costs, charges and expenses of any suit, action or proceedings arising out of such incident or injury and against all sum or sums which may

with the consent of the contractor be paid to compromise or compound any such claim. Without limiting his obligations and liabilities as above provided, the contractor shall insure against all claims, damages or compensation payable under the Workmen's Compensation Act 1923 or any modification thereof or any other law relating thereto.

PAYMENTS

- 1- Operations & Maintenance charges shall be pay **Quarterly Basis**.
- 2- All running payments shall be as payments for work actually done and completed and/or accepted by BSCDCL.
- 3- In case of SITC items the bidder will get the payment as follows:-
 - a) In case of supply 70%,
 - b) In case of Installation/Testing 20%
 - c) In case of Commissioning 10%
- 4- The recovery for bad, unsound and imperfect or unskilled work to be removed and taken away and reconstructed or re-erected or be considered as an admission of the due performance of the Contract, or any part thereof, in this respect, or the accruing of any claim, nor shall it conclude, determine or affect in any way the powers of the BSCDCL under these conditions or any of them as to the final settlement and adjustments of the accounts or otherwise, or in any other way vary/ affect the contract.
- 5- The final bill shall be submitted by the contractor within three months of the completion of work, otherwise BSCDCL's certificate of the measurement and of the total amount payable for the work accordingly shall be final and binding on contractor. It is clearly agreed and understood by the Contractor that notwithstanding anything to the contrary that may be stated in the agreement between BSCDCL and the contractor; the contractor shall become entitled to payment only after BSCDCL has received the corresponding payment(s) from the client/ Owner for the work done by the contractor.

Any delay in the release of payment by the client/ Owner to BSCDCL leading to a delay in the release the corresponding payment by BSCDCL to the contractor shall not entitle the Contractor to any compensation/ interest from BSCDCL.

All payments shall be released by way of e-transfer through RTGS/NEFT in India directly at their Bank account by BSCDCL.

MEASUREMENTS OF WORKS

Engineer-in-charge shall, except as otherwise provided, ascertain and determine by measurement, the value of work done in accordance with the contract. Except where any general or detailed description of the work expressly shows to the contrary, measurement shall be taken in accordance with the Procedure set forth in the UADD/MPPWD/CPWD Specification. In the case of items which are not covered by specifications, mode of measurement as specified in the Technical Specifications of the contract and if for any item no such technical specification is available, then a relevant standard method of measurement issued by the Bureau of Indian Standard shall be followed.

Provided further that, In case of Cancellation/Determination of Contract in Full or in Part in accordance with clause given in tender document (and its sub-clauses),

following methodology shall be adopted in respect of measurements in addition to what has been mentioned in foregoing:-

All measurements and levels shall be taken jointly by the Engineer-in-Charge or his authorized representative and by the contractor or his authorized representative from time to time during the progress of the work and such measurements shall be signed and dated by the Engineer-in-Charge and the contractor or their representatives in token of their acceptance. If the contractor objects to any of the measurements recorded, a note shall be made to that effect with reason and signed by both the parties.

If for any reason the contractor or his authorized representative is not available and the work of recording measurements is suspended by the Engineer-in-Charge or his representative, the Engineer-in-Charge and BSCDCL shall not entertain any claim from contractor for any loss or damages on this account. If the contractor or his authorized representative does not remain present at the time of such measurements after the contractor or his authorized representative has been given a notice in writing three (3) days in advance or fails to countersign or to record objection within a week from the date of the measurement, then such measurements recorded in his absence by the Engineer-in-Charge or his representative shall be deemed to be accepted by the Contractor. The contractor shall, without extra charge, provide all assistance with every appliance, labour and other things necessary for measurements and recording levels.

COMPUTERISED MEASUREMENT BOOKS

Engineer-in-Charge shall, except as otherwise provided, ascertain and determine by measurement the value of work done in accordance with the contract. All measurements of all items having financial value shall be entered by the contractor and compiled in the shape of the Computerized Measurement Book as per the format of BSCDCL so that a complete record is obtained of all the items of works performed under the contract. All such measurements and levels recorded by the contractor or his authorized representative from time to time, during the progress of the work, shall be got checked by the contractor from the Engineer-in-Charge or his authorized representative as per interval or program fixed in consultation with Engineer-in-Charge or his authorized representative.

After the necessary corrections made by the Engineer-in-Charge, the measurement sheets shall be returned to the contractor for incorporating the corrections and for resubmission to the Engineer-in-Charge for the dated signatures by the Engineer-in-Charge and the contractor or their representatives in token of their acceptance.

Whenever bill is due for payment, the contractor would initially submit draft computerized measurement sheets and these measurements would be got checked/test checked from the Engineer-in-Charge and/or his authorized representative. The contractor will, thereafter, incorporate such changes as may be done during these checks/test checks in his draft computerized measurements, and submit to BSCDCL a computerized measurement book, duly bound, and with its pages machine numbered. The Engineer-in-Charge and/or his authorized representative would thereafter check this MB, and record the necessary certificates for their checks/test checks.

The final, fair, computerized measurement book given by the contractor, duly bound, with its pages numbered, should be 100% correct, and no cutting or over-writing in the measurements would thereafter be allowed. If at all any error is noticed, the contractor shall have to submit a fresh computerized MB with its pages duly numbered and bound, after

getting the earlier MB cancelled by the BSCDCL. The contractor shall submit two spare copies of such computerized MB's for the purpose of reference and record by the various officers of the BSCDCL.

The contractor shall also submit to the department separately his computerized Abstract of Cost and the bill based on these measurements, duly bound, and its pages numbered along with two spare copies of the bill.

The contractor shall, without extra charge, provide all assistance with every appliance, labour and other things necessary for checking of measurements /levels by the Engineer-in-Charge or his representative.

The contractor shall give not less than seven days' notice to the Engineer-in-Charge or his authorized representative in charge of the work before covering up or otherwise placing beyond the reach of checking and/or test checking the measurement of any work in order that the same may be checked and/or test checked and correct dimensions thereof be taken before the same is covered up or placed beyond the reach of checking and/or test checking measurement and shall not cover up and place beyond reach of measurement any work without consent in writing of the Engineer-in-Charge or his authorized representative in charge of the work who shall within the aforesaid period of seven days inspect the work, and if any work shall be covered up or placed beyond the reach of checking and/or test checking measurements without such notice having been given or the Engineer-in-Charge's consent being obtained in writing the same shall be uncovered at the Contractor's expense, or in default thereof no payment or allowance shall be made for such work or the materials with which the same was executed.

Engineer-in-Charge or his authorized representative may cause either themselves or through another officer of the BSCDCL to check the measurements recorded by contractor and all provisions stipulated herein above or anywhere in the tender document shall be applicable to such checking of measurements or levels.

It is also a term of this contract that checking and/or test checking the measurements of any item of work in the measurement book and/or its payment in the interim, on account of final bill shall not be considered as conclusive evidence as to the sufficiency of any work or material to which it relates nor shall it relieve the contractor from liabilities from any over measurement or defects noticed till completion of the defects liability period.

WITHHOLDING AND LIEN IN RESPECT OF SUMS DUE FROM CONTRACTOR

Whenever any claim or claims for payment of a sum of money arises out of or under the contract or against the contractor, BSCDCL shall be entitled to withhold and also have a lien to retain such sum or sums in whole or in part from the security, if any, deposited by the contractor and for the purpose aforesaid, BSCDCL shall be entitled to withhold the Performance Guarantee, if any, furnished as the case may be and also have a lien over the same pending finalization or adjudication of any such claim. In the event of the security being insufficient to cover the claimed amount or amounts or if no security has been taken from the contractor, BSCDCL shall be entitled to withhold and have a lien to retain to the extent of such claimed amount or amounts referred to above, from any sum or sums found payable or which may at any time thereafter become payable to the contractor under the same contract or any other contract pending finalization of adjudication of any such claim.

It is an agreed term of the contract that the sum of money or moneys so withheld or retained under the lien referred to above by the Engineer-in-Charge or BSCDCL will be

kept withheld or retained as such by the Engineer-in-Charge or BSCDCL till the claim arising out of or under the contract is determined by the competent court and that the contractor will have no claim for interest or damages whatsoever on any account in respect of such withholding or retention under the lien referred to above and duly notified as such to the contractor. For the purpose of this clause, where the contractor is a partnership firm or a limited company, the Engineer-in-Charge or the BSCDCL shall be entitled to withhold and also have a lien to retain towards such claimed amount or amounts in whole or in part from any sum found payable to any partner/limited company, as the case may whether in his individual capacity or otherwise. BSCDCL shall have the right to cause an audit and technical examination of the works and the final bills of the contractor including all supporting vouchers, abstract, etc, to be made after payment of the final bill and if as a result of such audit and technical examination any sum is found to have been overpaid in respect of any work done by the contractor under the contract or any work claimed to have been done by him under the contract and found not to have been executed, the contractor shall be liable to refund the amount of over-payment and it shall be lawful for BSCDCL to recover the same from him in the manner prescribed in tender document of this clause or in any other manner legally permissible; and if it is found that the contractor was paid less than what was due to him under the contract in respect of any work executed by him under it, the amount of such under payment shall be duly paid by BSCDCL to the contractor, without any interest there on whatsoever.

LIEN IN RESPECT OF CLAIMS IN OTHER CONTRACTS

Any sum of money due and payable to the under the contract may be withheld or retained by way of lien by the Engineer-in-Charge or by BSCDCL against any claim of the Engineer-in-Charge or BSCDCL in respect to payment of a sum of money arising out of or under any other contract made by the contractor with the Engineer-in-Charge or the BSCDCL. It is an agreed term of the contract that the sum of money so withheld or retained under this clause by the Engineer-in-Charge or the BSCDCL will be kept withheld or retained as such by the Engineer-in-Charge or the BSCDCL or till his claim arising out of the same contract or any other contract is either mutually settled or determined by the competent court, as the case may be, and that the contractor shall have no claim for interest or damages whatsoever on this account or on any other ground in respect of any sum of money withheld or retained under this clause and duly notified as such to the contractor.

WORK TO BE EXECUTED IN ACCORDANCE WITH SPECIFICATIONS, DRAWINGS, AND ORDERS ETC.

All items of work in the bill of quantities/ schedule of quantities shall be carried out as per the UADD/MPPWD/CPWD/ BSCDCL specifications, drawings and instructions of the Engineer-in-Charge of BSCDCL and the rates shall include for supply of required materials including proper storage, consumables, skilled & unskilled labour, supervision and tools, tackles, plant & machinery complete as called for in the detailed specifications and conditions of the contract. Latest updated UADD/MPPWD/CPWD specification shall be followed for execution of work. The contractor shall execute the whole and every part of the work in the most substantial and workman like manner both as regards materials and otherwise in every respect in strict accordance with the specifications.

The contractor shall also conform exactly, fully and faithfully to the design, drawings and instructions in writing in respect of the work assigned by the Engineer-in- Charge.

The contractor shall comply with the provisions of the contract and execute the works with care and diligence and maintain the works and provide all labour and materials, tools and plants including for measurements and supervision of all works, structural plans and other things of temporary or permanent nature required for such execution and

maintenance in so far as the necessity for providing these, is specified or is reasonably inferred from the contract. The contractor shall take full responsibility for adequacy, suitability and safety of all the works and methods of construction.

MATERIALS TO BE PROVIDED BY THE CONTRACTOR

The contractor shall, at his own expense, provide all materials, required including Cement & Steel for the works. The contractor shall at his own expense and without delay; supply to the Engineer-in-Charge samples of materials to be used on the work and shall get the same approved in advance. All such materials to be provided by the Contractor shall be in conformity with the specifications laid down or referred to in the contract.

The contractor shall, if requested by the Engineer-in-Charge furnish proof, to the satisfaction of the Engineer-in-Charge that the materials so comply.

The contractor shall at his risk and cost, submit the samples of material to be tested or analyzed and bear all charges and cost of testing unless specifically provided for otherwise elsewhere in the contract or specifications. The Engineer - in- Charge or his authorized representative shall at all times have access to the works and to all workshops and places where work is being prepared or from where materials, manufactured articles or machinery are being obtained for the works and the contractor shall afford every facility and every assistance and cost in obtaining the right and visit to such access.

The Engineer-in-Charge shall have full powers to require the removal from the premises of all materials which in his opinion are not in accordance with the specifications and in case of default, the Engineer-in-Charge shall be at liberty to employ at the expense of the contractor, other persons to remove the same without being answerable or accountable for any loss or damage that may happen or arise to such materials. The Engineer-in-Charge shall also have full power to require other proper materials to be substituted thereof and in case of default, the Engineer-in- Charge may cause the same to be supplied and all costs which may require such removal and substitution shall be borne by the contractor.

MATERIALS AND SAMPLES

The materials/products used on the works shall be one of the approved make/ brands out of list of manufacturers / brands /makes given in the tender documents. The contractor shall submit samples/ specimens out of approved makes of materials/ products to the Engineer in-Charge for prior approval. In exceptional circumstances Engineer-in-Charge may allow alternate equivalent makes/brands of products/ materials at his sole discretion. The final choice of brand / make shall remain with the Engineer- in-Charge, whose decision in this matter shall be final and binding and nothing extra on this account shall be payable to the Contractor. In case single brand/ make are mentioned, other equivalent makes/ brands may be considered by the Engineer -in-Charge. In case of variance in UADD/MPPWD/CPWD/IS/BIS Specifications from approved products/makes specification, the specification of approved product/make shall prevail for which nothing shall be paid extra to the Contractor. In case no make or brand of any materials, articles, fittings and accessories etc. is specified, the same shall comply with the relevant Indian Standard

Specifications and shall bear the ISI/BIS mark. The Engineer of BSCDCL and the owner shall have the discretion to check quality of materials and equipments to be incorporated in the work, at source of supply or site of work and even after incorporation in the work. They shall also have the discretion to check the workmanship of various items of work to be executed in this work. The contractor shall provide the necessary facilities and assistance for this purpose.

The above provisions shall not absolve the contractor from the quality of final

product and in getting the material and workmanship quality checked and approved from the Engineer-in-Charge of BSCDCL.

The contractor shall well in advance, produce samples of all materials, articles, fittings, accessories etc. that he proposes to use and get them approved in writing by BSCDCL. The materials articles etc. as approved shall be LABELLED as such and shall be signed by BSCDCL and the Contractor's representative.

The approved samples shall be kept in the custody of the Engineer-in-Charge of BSCDCL till completion of the work. Thereafter the samples except those destroyed during testing shall be returned to the contractor. No payment will be made to the contractor for the samples or samples destroyed in testing.

The brands of all materials, articles fittings etc. approved together with the names of the manufacturers and firms from which supplies have been arranged shall be recorded in the site orderbook.

The contractor shall set up and maintain at his cost, a field testing laboratory for all day to day tests at his own cost to the satisfaction of the Engineer-in-Charge. This field testing laboratory shall be provided with equipment and facilities to carry out all mandatory field tests as per BSCDCL/UADD/MPPWD/CPWD (as the case may be) specifications. The laboratory building shall be constructed and installed with the appropriate facilities, Temperature and humidity controls shall be available wherever necessary during testing of samples. All equipments shall be provided by the Contractor so as to be compatible with the testing requirements specified. The Contractor shall maintain all the equipments in good working condition for the duration of the contract.

The Contractor shall provide approved qualified personnel to run the laboratory for the duration of the Contract. The number of staff and equipment available must at all times be sufficient to keep pace with the sampling and testing programme as required by the Engineer-in-charge. The Contractor shall fully service the site laboratory and shall supply everything necessary for its proper functioning, including all transport needed to move equipment and samples to and from sampling points on the site, etc. The Contractor shall re-calibrate all measuring devices whenever so required by the Engineer-in-charge and shall submit the results of such calibration without delay. All field test shall be carried out in the presence of BSCDCL's representative. All costs towards samples, materials, collection, transport, manpower, testing etc. shall be borne by the Contractor and are deemed to be included in the rates quoted by him in the bill of quantities.

The contractor(s) shall display the calibration certificate of each equipment at the location of equipment & shall get recalibrated at least one week before its expiry date.

MATERIALS PROCURED WITH THE ASSISTANCE OF BSCDCL

If any material for the execution of this contract is procured with the assistance of BSCDCL either by issue from its stores or purchase made under orders or permits or licenses obtained by BSCDCL, the contractor shall hold and use the said materials economically and solely for the purpose of this contract and shall not dispose them without the permission of Engineer-in-charge. The contractor, if required by the BSCDCL, shall return all such surplus or unserviceable materials that may be left with him after the completion of the contract or at its termination on whatsoever reason, on being paid or credited such price as the Engineer-in-charge shall determine having due regard to the conditions of materials. The price allowed to the contractor, however, shall not exceed the amount charged to him excluding the element of storage charges which shall be 10% of the cost charged to contractor. The decision of the Engineer-in-charge shall be final and conclusive. Contractor(s) has / have to deploy security personnel for safeguarding of materials procured at site.

CONTRACTOR TO SUPPLY TOOLS & PLANTS

The contractor shall provide at his own cost all materials, machinery, tools & plants as require for completion of work. In addition to this, appliances, implements, other plants, ladders, cordage, tackle, scaffolding and temporary works required for the proper execution of the work, whether original, altered or substituted and whether included in the specifications or other documents forming part of the contract or referred to in these conditions or not, or which may be necessary for the purpose of satisfying or complying with the requirements of the Engineer-in-Charge as to any matter as to which under these conditions he is entitled to be satisfied, or which he is entitled to require together with carriage therefore to and from the work. The contractor shall also supply without charge the requisite number of persons with the means and materials, necessary for the purpose of setting out works, and counting, weighing and assisting the measurement or examination at any time and from time to time of the work or materials. Failing his so doing, the same may be provided by the Engineer-in-Charge at the expense of the contractor and the expenses may be deducted, from any money due to the contractor, under this contract or otherwise and/or from his Performance Guarantee or the proceeds of sale thereof, or of a sufficient portion thereof.

MOBILIZATION OF MEN, MATERIALS AND MACHINERY:

All expenses towards mobilization at site and de-mobilization including bringing in equipment, work force, materials, dismantling the equipment's, clearing the site etc. shall be deemed to be included in prices quoted and no separate payment on account of such expenses shall be entertained.

It shall be entirely the Contractor's responsibility to provide, operate and maintain all necessary construction equipment's, scaffoldings and safety, gadget, lifting tackles, tools and appliances to perform the work in a workman like and efficient manner and complete all jobs as per the specifications and within the schedule time of completion of work. Further, contractor shall also be responsible for obtaining temporary electric and water connection for all purposes. The contractor shall also make standby arrangement for water & electricity to ensure un-interrupted supply. It shall be the responsibility of the contractor to obtain the approval for any revision and/or modification desired by him from BSCDCL before implementation.

The procurement and supply in sequence and at the appropriate time of all materials and consumable shall be entirely the contractor's responsibilities and his rates for execution of work shall be inclusive of supply of all these items.

It is mandatory for the contractor to provide safety equipment's and gadgets to his all workers, supervisory and Technical staff engaged in the execution of the work while working. The minimum requirement (but not limited to) shall be gum boots, safety helmets, Rubber hand gloves, face masks, safety nets, safety belts, goggles etc. as per work requirements. Sufficient nos. of these equipment's and gadgets shall also be provided to BSCDCL by the contractor at his own cost for use of BSCDCL Officials and/ or workforce while working/supervision of work at site. No staff/ worker shall be allowed to enter the site without these equipment's/ gadgets.

The cost of the above equipment's/ gadgets are deemed to be included in the rates quoted

by the contractor for the items & works as per Bill of Quantities and contractor shall not be entitled for any extra payment in these regard. The above norm is to be strictly complied with at site. In case the contractor is found to be deficient in providing Safety Equipment's/ Gadgets in the opinion of Engineer-in-charge, the Engineer-in-charge at his option can procure the same at the risk & cost of contractor and provide the same for the use of worksite and shall make the recoveries from the bills of the contractor for the same. The contractor shall abide by all rules & regulations pertaining to Health, Safety and Environment.

One copy of contract documents including drawings furnished to the contractor shall be kept at the site and the same shall at all reasonable times be available for inspection.

All materials, construction plants and equipments etc. once brought by the contractor within the project area, will not be allowed to be removed from the premises without the written permission of the Engineer-in-charge. Similarly all enabling works built by the contractor for the main construction undertaken by him, shall not be dismantled and removed without the written authority of the BSCDCL.

Contractor shall have to prepare the Bar Bending Schedule, shop and fabrication drawings free of cost, if required for any of the items of work.

Five copies of these drawings each including for revision will be submitted to BSCDCL for approval. Before executing the item, shop drawings and bar bending schedule should be approved by BSCDCL.

BSCDCL shall supply Work Force in the various categories to assist the contractor in execution of the works on recoverable basis as per provision mentioned elsewhere in the contract.

All contractor's plant, machinery and equipment shall be kept in perfect condition during currency of the contract.

QUALITY ASSURANCE PROGRAMME

To ensure that the services under the scope of this contract are in accordance with the specifications, the Contractor shall adopt Quality Assurance Programme to control such activities at the necessary points:

The contractor shall prepare and finalize such Quality Assurance Programme within 15 days from date of issue Letter of Award. BSCDCL shall also carry out quality audit and quality surveillance of systems and procedures of Contractor's quality control activities. A Quality Assurance Programme of Contractor shall generally cover the following:

His organization structure for the management and implementation of the proposed Quality Assurance Program.

- Documentation control system.
- The procedure for purpose of materials and source inspection.
- System for site controls including process controls.
- Control of non-conforming items and systems for corrective actions.
Inspection and test procedure for site activities.
- System for indication and appraisal of inspection status. System for maintenance of records.
- System for handling, storage and delivery.

- A quality plan detailing out quality practices and procedures, relevant standards and acceptance levels for all types of work under the scope of this contract.

All the quality reports shall be submitted by the Contractors in the formats appended hereto. Checklist enclosed here in this document shall be followed while carrying out Construction activities (items). If any item is not covered by the Checklist/Formats appended hereto, the Format for the same may be developed and submitted to Engineer-in-Charge for approval and the same shall be adopted. These filled in formats shall be prepared in two copies and duly signed by representatives of contractor and BSCDCL. All the costs associate with Printing of Formats and testing of materials required as per technical specifications or by Engineer-in-charge shall be included in the Contractor's quoted rates in the Schedule/ Bill of quantities.

CONTRACT COORDINATION PROCEDURES, COORDINATION MEETINGS AND PROGRESS REPORTING

The Contractor shall prepare and finalize in consultation with BSCDCL, a detailed contract coordination procedure within 15 days from the date of issue of Letter of Award for the purpose of execution of the Contract. The Contractor shall have to attend all the meetings at any place in India at his own cost with BSCDCL, Owners/ Clients or Consultants of BSCDCL/ Owner/ Client during the currency of the Contract, as and when required and fully cooperate with such personal and agencies involved during these discussions. The Contractor shall not deal in any way directly with the Clients/ Owners or Consultants of BSCDCL/Owner/ Clients and any dealing/correspondence if required at any time with Clients/ Owners/ Consultants shall be through BSCDCL only. During the execution of the work, Contractor shall submit at his own cost a detailed Monthly progress & programme report to the Engineer-in-charge of BSCDCL by 5th of every month. The format of monthly progress & programme report shall be as approved by Engineer-in-Charge of BSCDCL.

COMPLETION CERTIFICATE AND COMPLETION PLANS

Within ten days of the completion of the work, the contractor shall give notice of such completion to the Engineer-in-Charge and within thirty days of the receipt of such notice, the Engineer-in-Charge shall inspect the work and if there is no defect in the work, shall furnish the contractor with a final certificate of completion, otherwise a provisional certificate of physical completion indicating defects (a) to be rectified by the contractor and/or

(b) for which payment will be made at reduced rates, shall be issued. But no final certificate of completion shall be issued, nor shall the work be considered to be complete until the contractor shall have removed from the premises on which the work shall be executed all scaffolding, surplus materials, rubbish and all huts and sanitary arrangements required for his/their work people on the site in connection with the execution of the works as shall have been erected or constructed by the contractor(s) and cleaned off the dirt from all wood work, doors, windows, walls, floor or other parts of the building, in, upon, or about which the work is to be executed or of which he may have had possession for the purpose of the execution; thereof, and not until the work shall have been measured by the Engineer-in-Charge. If the contractor shall fail to comply with the requirements of this Clause as to removal of scaffolding, surplus materials and rubbish and all huts and sanitary arrangements as aforesaid and cleaning off dirt on or before the date fixed for the completion of work, the Engineer-in-Charge may at the expense of the contractor remove

such scaffolding, surplus materials and rubbish etc., and dispose of the same as he thinks fit and clean off such dirt as aforesaid, and the contractor shall have no claim in respect of scaffolding or surplus materials as aforesaid except for any sum actually realized by the sale thereof less actual cost incurred on removal of materials / debris / malbaetc.

The contractor shall submit completion plan as required vide General Specifications for Electrical works as applicable within thirty days of the completion of the work. In case, the contractor fails to submit the completion plan as aforesaid, he shall be liable to pay a sum equivalent to 2.5% of the value of the work subject to a ceiling of Rs.5,00,000 (Rs. Five Lakhs only) as may be fixed by the Engineer-in-charge concerned and in this respect the decision of the Engineer-in-charge shall be final and binding on the contractor.

PROHIBITION OF UNAUTHORISED CONSTRUCTION & OCCUPATION

No unauthorized buildings, construction of structures should be put up by the contractor anywhere on the project site, neither any building built by him shall be occupied in un-authorized manner by him or his staff.

It shall be the responsibility of the contractor to see that the building under construction is not occupied by anybody in un-authorized manner during construction, and is handed over to the Engineer-in-Charge with vacant possession of complete building. If such building though completed is occupied illegally, then the Engineer-in-Charge shall have the option to refuse to accept the said building/buildings in that position. Any delay in acceptance on this account will be treated as the delay in completion and for such delay, a levy of compensation upto 5% of tendered value of work may be imposed by the Engineer-in-Charge whose decision shall be final both with regard to the justification and quantum and shall be binding on the contractor.

However, the Engineer-in-Charge, through a notice, may require the contractor to remove the illegal occupation any time on or before construction and delivery.

FORECLOSURE OF CONTRACT BY BSCDCL/OWNER

If at any time after the commencement of the work the BSCDCL shall for any reason whatsoever is required to abandon the work or is not require the whole work thereof as specified in the tender to be carried out, the Engineer-in-Charge shall give notice in writing of the fact to the contractor, who shall have no claim to any payment of compensation whatsoever on account of any profit or advantage which he might have derived from the execution of the work in full, but which he did not derive in consequence of the foreclosure of the whole or part of the works.

DEFECTS LIABILITY PERIOD

The contractor shall be responsible for the rectification of defects in the works for a period twelve months from the date of taking over of the works by the BSCDCL or clients whichever is later. Any defects discovered and brought to the notice of the contractor forthwith shall be attended to and rectified by him at his own cost and expense. In case the contractor fails to carry out these rectifications, the same may without prejudice to any other right or remedy available, be got rectified by BSCDCL at the cost and expense of the contractor

RESTRICTION ON SUBLETTING

The contractor shall not sublet or assign the whole or part of the works except where otherwise provided, by the contract. The provision of labour on piece work basis shall not be deemed to be a subletting under this clause.

The contractor may entrust specialist items of works like MEP services, HVAC, Lifts, Building Management System, Water Proofing, and Data & Communication networking, interiors, landscaping etc. to the agencies specialized in the specific trade. The contractor shall give the names and details of such firm whom it is going to employ for approval of BSCDCL. These details shall include the expertise, financial status, technical manpower, equipment, resources and list of works executed and on hand of the specialist agency. Further, prior written approval is required from BSCDCL to deploy such agency / sub-contractor.

FORCE MAJEURE

Any delay in or failure to perform of either party, shall not constitute default so as to give rise to any claim for damages, to the extent such delay or failure to perform is caused by an act of God, or by fire, explosion, flood or other natural catastrophe, governmental legislation, orders or regulation etc. Failure of the client / owner to hand over the entire site and / or release funds for the project, to BSCDCL, shall also constitute force majeure. The time for performance of the obligation by the parties shall be deemed to be extended for a period equal to the duration of the force majeure event. Both parties shall make their best efforts to minimize the delay caused by the force majeure event. If the failure / delay of the client /owner in handing over the entire site and / or in releasing the funds continues even on the expiry of the stipulated date of completion, BSCDCL, may, at the request of the contractor, foreclose the contract without any liability to either party. In the event of such foreclosure, the contractor shall not be entitled to any compensation whatsoever. If prior to such foreclosure the contractor has brought any materials to the site, the Engineer-in-Charge shall always have the option of taking over of all such materials at their purchase price or at the local current rates, whichever is lower.

NO COMPENSATION CLAUSE

The contractor shall have no claim whatsoever for compensation or idle charges against BSCDCL on any ground or for any reason, whatsoever.

DIRECTION FOR WORKS

All works under the contract shall be executed under the direction and subject to approval in all respect of the Engineer-in-Charge of BSCDCL who shall be entitled to direct at whatever point or points and in whatever manner works are to be commenced and executed.

The Engineer-in-Charge and his representative shall communicate or confirm their instructions to the contractor in respect of the execution of work during their site inspection in a „Works Site Order Book“ maintained at the site office of Engineer-in-Charge. The contractor or his authorized representative shall confirm receipt of such instructions by signing against the relevant orders in the book.

WORK IN MONSOON AND RAIN

The execution of the work may entail working in the monsoon also. The contractor must maintain labour force as may be required for the job and plan and execute the construction and erection according to the prescribed schedule. No special/ extra rate will be considered for such work in monsoon. The contractors' rate shall be considered inclusive of cost of dewatering due to rains required if any and no extra rate shall be payable on this account. The stipulated period for completion of project includes the monsoon period,

holidays & festivals.

WORK ON SUNDAYS, HOLIDAYS AND DURING NIGHT

For carrying out work on Sunday and Holidays or during night, the contractor will approach the Engineer-in-Charge or his representative at least two days in advance and obtain his permission. The Engineer-in-Charge at his discretion can refuse such permission. The contractor shall have no claim on this account whatsoever. If work demand, the contractor shall make arrangements to carry out the work on Sundays, Holidays and in two, three shifts with the approval of Engineer-in-Charge at no extra cost to BSCDCL.

WATER AND ELECTRICITY

The contractor shall make his own arrangement for Water & Electrical power for construction and other purposes at his own cost and pay requisite electricity and water charges. The contractor shall also make standby arrangement for water & electricity to ensure un-interrupted supply.

LAND FOR LABOUR HUTS/ SITE OFFICE AND STORAGE ACCOMMODATION

The contractor shall arrange the land for temporary office, storage accommodation and labour huts at his own cost and get the clearance of local authorities for setting up/construction of labour camp and same is deemed to be included in the rates quoted by the contractor for the works. The contractor shall ensure that the area of labour huts is kept clean and sanitary conditions are maintained as laid down by the local authorities controlling the area. The labour huts shall be so placed that it does not hinder the progress of work or access to the worksite. The vacant possession of the land used, for the purpose shall be given back by contractor after completion of the work.

WATCH, WARD AND LIGHTING OF WORK PLACE

The contractor shall at his own cost take all precautions to ensure safety of life and property by providing necessary barriers, OBSTRUCTIONS, lights, watchmen etc. during the progress of work as directed by Engineer-in-charge.

SCHEDULE OF QUANTITIES / BILL OF QUANTITIES

The quantities shown against the various items of work are only approximate quantities which may vary as per the actual requirement at site. No item which is not covered in the bill of quantities shall be executed by the Contractor without the approval of the BSCDCL. In case any Extra/Substituted item is carried out without specific-approval, the same will not be paid.

INDIAN STANDARDS

Wherever any reference is made to any IS in any particular specifications, drawings or bill of quantities, it means the Indian Standards editions with up to date amendments issued till last date of receipt of tender documents.

TESTS AND INSPECTION

The contractor shall carry out the various mandatory tests as per specifications and the technical documents that will be furnished to him during the performance of the work. All the tests on materials, as recommended by UADD/MPPWD/CPWD, BSCDCL and relevant Indian Standard Codes or other standard specifications (including all amendments current at the last date of submission of tender documents) shall be got carried out by the

contractor at the field testing laboratory or any other recognized institution/ laboratory, at the direction of the BSCDCL. All testing charges, expenses etc. shall be borne by the contractor. All the tests, either on the field or outside laboratories concerning the execution of the work and supply of materials shall be got carried out by the contractor or BSCDCL at the cost of the Contractor.

WORKS TO BE OPEN TO INSPECTION

All works executed or under the course of execution in pursuance of this contract shall at all times be open to inspection and supervision of the BSCDCL. The work during its progress or after its completion may also be inspected, by Chief Technical Examiner of Government of India (CTE) and/or an inspecting authority of State Government of State in which work is executed and/or by third party checks by owner/clients. The compliance of observations/improvements as suggested by the inspecting officers of BSCDCL/CTE/ State authorities/ Owners shall be obligatory on the part of the Contractor at the cost of contractor.

CARE OF WORKS

From the commencement to the completion of works and handing over, the contractor shall take full responsibility for care thereof of all the works and in case of any damage/loss to the works or to any part thereof or to any temporary works due to lack of precautions or due to negligence on part of Contractor, the same shall be made good by the Contractor.

CO-ORDINATION WITH OTHER AGENCIES

Work shall be carried out in such a manner that the work of other Agencies operating at the site is not hampered due to any action of the Contractor. Proper Co-ordination with other Agencies will be Contractor's responsibility. In case of any dispute, the decision of BSCDCL shall be final and binding on the contractor. No claim whatsoever shall be admissible on this account.

SETTING OUT OF THE WORKS

The contractor shall be responsible for the true and proper setting out of the works and for the correctness of the position, levels, dimensions and alignment of all parts of the works. If at any time during the progress of works, shall any error appear or arise in the position, levels, dimensions or alignment of any part of the works, the contractor shall at his own expenses rectify such error to the satisfaction of Engineer-in-charge. The checking of any setting out or of any line or level by the engineers of BSCDCL shall not in any way relieve the contractor of his responsibility for the correctness.

NOTICE BEFORE COVERING UP THE WORK

The contractor shall give not less than seven day's notice before covering up or otherwise placing beyond the reach of measurement any work, to the Engineer-in-charge in order that the same may be inspected and measured. If any work is covered up or placed beyond the reach of inspection/measurement without such notice or his consent being obtained the same shall be uncovered at the contractor expenses and he shall have to make it good at his own expenses.

SITE CLEARANCE

The contractor shall ensure that the working site is kept clean and free of obstructions for easy access to job site and also from safety point of view. Before handing over the work to the BSCDCL the contractor shall remove all temporary structures like the site offices, cement go-down, stores, labour hutments etc., scaffolding rubbish, debris etc. left over materials tools and plants, equipments etc., clean the site to the entire satisfaction of the Engineer-in-charge. If this is not done the same will be got done by BSCDCL at his risk and cost.

The contractor shall clean all floors, remove cement/ lime/ paint drops and deposits, clean joinery, glass panes etc., touching all painter's works and carry out all other necessary items of works to make the premises clean and tidy before handing over the building, and the rates quoted by the contractor shall be deemed to have included the same.

SET-OFF OF CONTRACTOR'S LIABILITIES

BSCDCL shall have the right to deduct or set off the expenses incurred or likely to be incurred by it in rectifying the defects and/or any claim under this agreement against the Contractor from any or against any amount payable to the contractor under this agreement including of performance guarantee.

POSSESSION PRIOR TO COMPLETION

BSCDCL shall have the right to take possession of or use any completed or partially completed work or part of the work. Such possession or use shall not be deemed to be any acceptance of any work not completed in accordance with the contract agreement. If such prior possession or use by BSCDCL delays the progress of work an equitable adjustment in the time of completion will be made and the contract agreement shall be deemed to be modified accordingly. The decision of BSCDCL in such case shall be final binding and conclusive.

When the whole of the works or the items or the groups of items of work have been completed the contractor will give a notice to that effect to the Engineer in writing. The Engineer shall within 7 days of the date of receipt of such notice inspect the works and give instructions in writing to the contractor specifying the balance items of work which are required to be done by the contractor and shall also notify the contractor of any defect in the works affecting completion.

The contractor shall during the course of execution prepare and keep updated a complete set of „as built“ drawings to show each and every change from the contract drawings, changes recorded shall be countersigned by the Engineer- in- Charge and the contractor. Four copies of „as built“ drawings shall be supplied to BSCDCL by the contractor within 30 days of the completion. All costs incurred in this respect shall be borne by the contractor.

EMPLOYMENT OF PERSONNEL

The contractor shall employ only Indian Nationals as his representatives, servants and workmen after verifying their antecedents and loyalty. He shall ensure that no personnel of doubtful antecedents and any other nationality in any way is associated with the works.

In case BSCDCL observed misconduct negligence or incompetence etc. on the part of any representative, agent, servant and workmen or employees etc. of the contractor, the BSCDCL shall have full power and without giving any reason to the contractor, instruct the contractor to remove such engineer / staff / worker from site and provide suitable replacements. The decision of the Engineer-in-charge shall be final and binding on the contractor. The contractor shall not be allowed any compensation on this account.

TECHNICAL STAFF FOR WORK

The contractor shall employ at his cost the adequate number of technical staff during the execution of this work depending upon the requirement of work. For this purpose the numbers to be deployed, their qualification, experience as decided by BSCDCL shall be final and binding on contractor. The contractor shall not be entitled for any extra payment in this regard.

The technical staff should be available at site, whenever required by BSCDCL to take instructions.

Within 15 days of Letter of Award, the contractor shall submit a site organizational chart and resume including details of experience of the Project-in-Charge and other staff proposed to be deputed by him and the technical team shall be deputed by them on the Project after getting approval from Engineer-in-Charge. If desired by the contractor at later date, the Project-in-Charge and other staff whose resume is approved by BSCDCL can be replaced with prior written approval of BSCDCL and replacement shall be with equivalent or superior candidate only. Decision of Engineer-in-Charge shall be final and binding on the contractor.

Even after approving the site organizational chart, the Engineer-in-Charge due to technical reasons and exigency of work can direct the contractor to depute such additional staff as in view of Engineer-in-Charge is necessary and having qualification and experience as approved by the Engineer-in-Charge. The removal of such additional staff from the site shall only be with the prior written approval of Engineer-in-Charge. The contractor shall not be paid anything extra whatsoever on account of deployment of additional staff and decision of the Engineer-in- Charge shall be final and binding on the contractor.

In case the contractor fails to employ the staff as aforesaid he shall be liable to pay a reasonable amount not exceeding a sum of Rs. 50,000/- (Rupees Fifty Thousand only) for each month of default in the case of each person. The decision of the Engineer-in-charge as to number of Technical Staff to be adequate for the project and the period for which the desired strength of technical staff was not employed by the contractor and as to the reasonableness of the amount to be deducted on this account shall be final and binding on the contractor as to the amount and the contractor's liability to pay the said amount.

VALUABLE ARTICLES FOUND AT SITE

All gold, silver and other minerals of any description and all precious stones, coins, treasure, relics, antiques and all other similar things which shall be found in, under or upon the site, shall be the property of the owner/ BSCDCL.

MATERIALS OBTAINED FROM DISMANTLEMENT TO BE OWNER'S

PROPERTY

All materials like stone, boulders and other materials obtained during the work of dismantling, excavation etc. will be considered BSCDCL/owner property and such materials shall be disposed off to the best advantage of BSCDCL/owner according to the instructions in writing issued by the Engineer-in-charge.

FURNISHED OFFICE ACCOMMODATION & MOBILITY COMMUNICATION TO BE ARRANGED BY CONTRACTOR

On acceptance of tender, the contractor at his own cost will construct a suitably equipped office at site with basic facilities such as telephone(s), Email, internet, photocopier, computer(s) and printer(s) along with operator(s), regular electric & drinking water supply and staff carrying vehicles for the supervisory staff with driver, fuel and maintenance etc. as per the requirement of the project. The contractor shall maintain the aforesaid facilities intact/operational during the tenancy of the contract or maximum up to 6-months beyond the stipulated contractual completion date if the work is delayed due to any reasons. Operation and maintenance cost of all such materials, equipments / services shall be borne by the contractor.

The contractor shall also make sufficient arrangement for photography/video-graphy so that photographs video can be taken of any specific activity at any point of time. The contractor shall also make arrangement of software like MS Project etc. for the purpose of preparing progress report etc.

The contractor shall make all arrangements for ground breaking ceremony/inaugural function etc. for the project as required and the cost towards it deemed to be included in his rates/offer. Any expenditure already incurred/to be incurred by BSCDCL, shall be recovered from the contractor.

LABOUR LAWS –

LABOUR LAWS TO BE COMPLIED BY THE CONTRACTOR

The contractor shall obtain a valid license under the contract labour (Regulation & Abolition) Act 1970 and the contract labour Act (Regulation & Abolition) Central Rules 1971 and amended from time to time, and continue to have a valid license until the completion of the work including defect liability period. The contractor shall also adhere by the provision of the child labour (Prohibition and Regulation) Act. 1986 and as amended from time to time.

The contractor shall also comply with the provisions of the building and other Construction Workers (Regulation of Employment & Conditions of Service) Act, 1996 and the building and other Construction Workers Welfare Cess Act, 1996.

Any failure to fulfil above requirement shall attract the penal provisions of this contract arising out the resultant for non execution of the work before the commencement of work. No labour below the age of 18 years shall be employed on the work.

Payment of wages:

The contractor shall pay to labour employed by him either directly or through subcontractors, wages not less than fair wages as defined in the BSCDCL Contractor's Labour Regulations or as per the provisions of the Contract Labour (Regulation and Abolition) Act, 1970 and the contract Labour (Regulation and Abolition) Central Rules, 1971, wherever applicable.

The contractor shall, notwithstanding the provisions of any contract to the contrary, cause to be paid fair wage to labour indirectly engaged on the work, including any labour engaged by his sub-contractors in connection with the said work, as if the labour had been immediately employed by him

In respect of all labour directly or indirectly employed in the works for performance of the contractor's part of this contract, the contractor shall comply with or cause to be complied with the BSCDCL contractor's Labour Regulations in regard to payment of wages, wage period, deductions from wages recovery of wages not paid and deductions unauthorisedly made, maintenance of wage books or wage slips, publication of scale of wages and other terms of employment, inspection and submission of periodical returns and all other matters of the like nature or as per the provisions of the Contract Labour (Regulation and Abolition) Act, 1970, and the Contract Labour (Regulation and Abolition) Central Rules, 1971, wherever applicable.

(a) The Engineer-in-Charge concerned shall have the right to deduct from the moneys due to the contractor any sum required or estimated to be required for making good the loss suffered by a worker or workers by reason of non-fulfilment of the conditions of the contract for the benefit of the workers, non-payment of wages or of deductions made from his or their wages which are not justified by their terms of the contract or non-observance of the Regulations.

(b) Under the provision of Minimum Wages (Central) Rules, 1950, the contractor is bound to allow to the labours directly or indirectly employed in the works one day rest for 6 days continuous work and pay wages at the same rate as for duty. In the event of default, the Engineer-in-Charge shall have the right to deduct the sum or sums not paid on account of wages for weekly holidays to any labours and pay the same to the persons entitled thereto from any money due to the contractor by the Engineer-in-Charge concerned

The contractor shall comply with the provisions of the Payment of Wages Act, 1936, Minimum Wages Act, 1948, Employees Liability Act, 1938, Workmen's Compensation Act, 1923, Industrial Disputes Act, 1947, Maternity Benefits Act,

1961, and the Contractor's Labour (Regulation and Abolition) Act 1970, or the modifications thereof or any other laws relating thereto and the rules made there under from time to time.

The contractor shall indemnify and keep indemnified BSCDCL against payments to be made under and for the observance of the laws aforesaid and the BSCDCL Contractor's Labour Regulations without prejudice to his right to claim indemnity from his sub-contractors.

The laws aforesaid shall be deemed to be a part of this contract and any breach thereof shall be deemed to be a breach of this contract.

LABOUR SAFETY PROVISION

The contractor shall be fully responsible to observe the labour safety provisions:

The contractor shall at his own cost take all precautions to ensure safety of life and property by providing necessary barriers, lights, watchmen etc. during the progress of work as directed by Engineer-in-charge.

In case of all labour directly or indirectly employed in work for the performance on the contractor's part of this contract, the contractor shall comply with all rules framed by Govt. from time to time for the protection of health and sanitary arrangements for workers.

OBSERVANCE OF LABOUR LAWS

The contractor shall be fully responsible for observance of all labour laws applicable including local laws and other laws applicable in this matter and shall indemnify and keep indemnified BSCDCL against effect or non observance of any such laws. The contractor shall be liable to make payment to all its employees, workers and sub-contractors and make compliance with labour laws. If BSCDCL or the client/ owner is held liable as "Principal Employer" to pay contributions etc. under legislation of Government or Court decision in respect of the employees of the contractor, then the contractor would reimburse the amount of such payments, contribution etc. to BSCDCL and/ or same shall be deducted from the payment of the contractor.

The Contractor shall submit proof of having valid EPF registration certificate. He shall within 7 days of the close of every month, submit to BSCDCL a statement showing the recoveries of contributions in respect of each employee employed by or through him and shall furnish to BSCDCL such information as the BSCDCL is required to furnish under the provisions of para 36 B of the EPF scheme 1952 to the EPF authorities and other information required by EPFO authorities from time to time. He shall also submit a copy of challan every month in token of proof of having deposited the subscription and contribution of workers engaged on the project.

In case, the contractor is not complying the above provision BSCDCL shall withhold payment to the extent of 4.70% (Four point Seven Zero percent) of the value of the Running Account bill and shall release only after the submission of above mentioned details. If it is incumbent upon BSCDCL to deposit withhold amount with EPF authorities, the withhold amount shall be deposited by BSCDCL with EPF authorities. In such a case BSCDCL shall not refund this withheld amount to the contractor even after the production of EPF registration certificate.

MINIMUM WAGES ACT

The contractor shall comply with all the provisions of the minimum wages Act, 1948, contract labour Act (Regulation & Abolition) 1970, and rules framed there under and other labour laws/local laws affecting contract labour that may be brought into force from time to time.

LABOUR CESS

The rates of the contractor shall be inclusive of labour cess. BSCDCL shall make a recovery @ 1% on account of labour cess from each RA bill of the contractor and labour cess so recovered/deducted shall be deposited with the Labour Board of the concerned state. In case the Labour Board is not established in the state, recovery made by BSCDCL on account of labour cess shall be retained under suspense account and will be deposited with the Labour Board at later date as & when the Labour Board is

constituted in the state.

Every contractor, sub-contractor, affiliates, their legal assigns or heirs as the case may, shall be responsible for registration of every Building worker who has completed eighteen years of age but has not completed sixty years of age and who has been engaged in any Building or Other Construction Work for not less than Ninety Days during the preceding twelve months; with the Board / Funds as applicable under various sections of "THE BUILDINGS AND OTHER.

CONSTRUCTION WORKERS (REGULATION OF EMPLOYMENT AND CONDITIONS OF SERVICE) ACT, 1996 and THE BUILDING AND OTHER CONSTRUCTION WORKERS' WELFARE CESS ACT, 1996.

The contractor shall also be responsible for maintaining register of beneficiaries i.e. the workers in such form as may be prescribed by the competent authority & the same shall be kept open at all reasonable times for inspection of relevant authority and officials of client / BSCDCL.

The contractor shall be further responsible for maintaining such register & records; giving such particulars of Building workers employed by him, the work performed by them, the number of hours of work which shall constitute a normal working day, the wages paid to them, the receipts given by them and, such other particulars in such form as may be prescribed by the authority or BSCDCL.

In the event of contractor failing to comply with the above clause(s) in part or in full, BSCDCL, without prejudice to any other rights or remedy available under law or any other clause(s) of contract, shall be at absolute liberty to forfeit any sum or sums that are payable or could become payable on account of execution of contract work and decision of Engineer-in-charge shall be final & binding in this regard on the contractor.

RECOVERY OF COMPENSATION PAID TO WORKMEN

In every case in which by virtue of the provisions sub-section (1) of Section 12, of the Workmen's Compensation Act, 1923, BSCDCL is obliged to pay compensation to a workman employed by the contractor, in execution of the works, BSCDCL will recover from the contractor, the amount of the compensation so paid; and, without prejudice to the rights of the BSCDCL under sub-section (2) of Section 12, of the said Act, BSCDCL shall be at liberty to recover such amount or any part thereof by deducting it from the Performance Guarantee or from any sum due to the contractor whether under this contract or otherwise. BSCDCL shall not be bound to contest any claim made against it under sub-section (1) of Section 12, of the said Act, except on the written request of the contractor and upon his giving to BSCDCL full security for all costs for which BSCDCL might become liable in consequence of contesting such claim.

ENSURING PAYMENT AND AMENITIES TO WORKERS IF CONTRACTOR FAILS

In every case in which by virtue of the provisions of the Contract Labour (Regulation and Abolition) Act, 1970, and of the Contract Labour (Regulation and Abolition) Central Rules, 1971, BSCDCL is obliged to pay any amounts of wages to a workman employed by the contractor in execution of the works, or to incur any expenditure in providing welfare and health amenities required to be provided under the above said Act or under the BSCDCL Contractor's Labour Regulations, or under the Rules framed by

Government from time to time for the protection of health and sanitary arrangements for workers employed by BSCDCL's Contractors, BSCDCL will recover from the contractor, the amount of wages so paid or the amount of expenditure so incurred; and without prejudice to any other right or remedy available under this contract, BSCDCL shall be at liberty to recover such amount or any part thereof by deducting it from any sum due by BSCDCL to the contractor whether under this contract or otherwise BSCDCL shall not be bound to contest any claim made against it under sub-section (1) of Section 20, sub-section (4) of Section 21, of the said Act, except on the written request of the contractor and upon his giving to the BSCDCL full security for all costs for which BSCDCL might become liable in contesting such claim.

CHANGE IN FIRM'S CONSTITUTION TO BE INTIMATED

Where the contractor is a partnership firm, the prior approval in writing of the Engineer-in-Charge shall be obtained before any change is made in the constitution of the firm. Where the contractor is an individual or a Hindu undivided family business concern such approval as aforesaid shall likewise be obtained before the contractor enters into any partnership agreement where under the partnership firm would have the right to carry out the works hereby undertaken by the contractor. If prior approval as aforesaid is not obtained, the contract shall be deemed to have been assigned in contravention of Clause of tender document hereof and the same action may be taken, and the same consequences shall ensue as provided in the tender document

INDEMNITY AGAINST PATENT RIGHTS

The contractor shall fully indemnify the BSCDCL from and against all claims and proceedings for or on account of any infringement of any patent rights, design, trademark or name or other protected rights in respect of any construction plant, machine, work or material used for in connection with the works or temporary works.

LAW COVERING THE CONTRACT

This contract shall be governed by the Indian laws for the time being in force.

LAWS, BYE-LAWS RELATING TO THE WORK

The contractor shall strictly adhere by the provisions, for the time being in force, of law relating to works or any regulations and bylaws made by any local authority or any water & lighting agencies or any undertakings within the limits of the jurisdiction of which the work is proposed to be executed. The contractor shall be bound to give to the authorities concerned such notices and take all approvals as may be provided in the law, regulations or bylaws as aforesaid, and to pay all fees and taxes payable to such authorities in respect thereof.

CONTRACT AGREEMENT

The Contractor shall enter into a Contract Agreement with the BSCDCL within 10 (TEN) days from the date of Letter of Award or within such extended time, as may be granted by the BSCDCL failing which no payment shall be released to the contractor. The cost of stamp papers, stamp duty, registration, if applicable on the contract, shall be borne by the Contractor. In case, the contractor does not sign the agreement as above or start the work within 10 (Ten) days of the issue of letter of Award, his earnest money is liable to be forfeited and Letter of award consequently will stand withdrawn.

MANNER OF EXECUTION OF AGREEMENT

The agreement as per prescribed Performa as enclosed shall be signed at the office of the BSCDCL within 10 (TEN days) days from the date of issue of Letter of Award. The Contractor shall provide for signing of the Contract, appropriate Power of Attorney and the requisite documents/ materials. Unless and until a formal contract is prepared and executed, the Letter of Award read in conjunction with the Tendering Documents will constitute a binding contract.

The agreement will be signed in five originals and the Contractor shall be provided with one signed original and the other four originals will be retained by the BSCDCL

The Contractor shall provide free of cost to the BSCDCL all the Engineering data, drawings and descriptive materials submitted along with the tender, in at least three (3) copies to form an integral part of the Agreement within seven 7 days after issuing of Letter of Award.

Subsequent to signing of the Agreement, the Contractor at his own cost shall provide to the BSCDCL with at least five (5) true hard bound copies of Agreement within thirty (30) days of its signing.

JURISDICTION

The agreement shall be executed at BHOPAL on non-judicial stamp paper purchased in BHOPAL and the courts in BHOPAL alone will have jurisdiction to deal with matters arising there from, to the exclusion of all other courts.

ARBITRATION

1. Arbitration Procedure: If the efforts, to resolve all or any of the disputes through conciliation fail, then such a dispute shall be referred within 30 days from conclusion of conciliation process to a Sole Arbitrator who would be nominated by Executive Director Bhopal Smart City Development Corporation Limited, Bhopal. The arbitration and conciliation act 1996 as amended from time to time will be applicable. The venue of such arbitration shall be at Bhopal. The award of the sole Arbitrator shall be binding on all parties. The cost of Arbitration shall be borne by the respective parties. There will be no objections if the sole arbitrator nominated or appointed is an employee of BSCDCL.

2. The place of arbitration shall be Bhopal, M.P.

3. English Language: The request for arbitration, the answer to the request, the terms of reference, any written submissions, any orders and awards shall be in English and, if oral hearings take place, English shall be the language to be used in the hearings. The award shall be made in writing.

4. Enforcement of Award: The Parties agree that the decision or award, which shall be a speaking order, resulting from arbitration shall be final and binding upon the Parties and shall be enforceable in accordance with the provision of the Arbitration and Conciliation Act 1996 subject to the rights of the aggrieved parties to secure relief from any higher forum.

5. Performance during Arbitration: The Arbitration Proceedings shall be governed by Indian Arbitration and Conciliation Act 1996, as amended from time to time including provisions in force at the time the reference is made. Pending the submission of and/or decision on a Dispute and until the arbitral award is published; the Parties shall continue to perform their respective obligations under this Agreement without prejudice to a final adjustment in accordance with such award. The courts at Bhopal shall have the sole exclusive jurisdiction to try all the cases arising out of this agreement.

6. Notices: That any notice under the terms of this License shall be in writing by registered post or delivered personally and signed by the party or his/its duly authorized representative giving such notice. All activities including day to day management, billing, termination etc. will be carried out from the office of the CEO, Smart City Development Corporation Limited Bhopal or by his duly authorized representative. Notice shall be addressed as follows:

Chief Executive Officer

SECTION-4

LABOUR SAFETY, HEALTH & SANITARY RULES AND REGULATIONS INCLUDING FORMS

LABOUR SAFETY PROVISIONS

Suitable scaffolds should be provided for workmen for all works that cannot safely be done from the ground, or from solid construction except such short period work as can be done safely from ladders. When a ladder is used an extra mazdoor shall be engaged for holding the ladder and if the ladder is used for carrying materials as well, suitable footholds and hand holds shall be provided on the ladder and the ladder shall be given an inclination not steeper than ¼ to 1 (1/4 horizontal and 1vertical).

Scaffolding or staging more than 3.6m (12 feet) above the ground or floor, swung or suspended from an overhead support or erected with stationery support shall have a guard rail properly attached or bolted, braced and otherwise secured at least 90 cm. (3 feet) high above the floor or platform of such scaffolding or staging and extending along the entire length of the outside and ends thereof with only such opening as may be necessary for the delivery of materials. Such scaffolding or staging shall be so fastened as to prevent it from swaying from the building or structure.

Working platforms, gangways, and stairways should be so constructed that they should not sag unduly or unequally, and if the height of the platform or the gangway or the stairway is more than 3.6m (12 feet) above ground level or floor level, they should be closely boarded, should have adequate width & should be suitable fastened as described in (2.0)above.

Every opening in the floor of a building or in a working platform shall be provided with suitable means to prevent the fall of persons or materials by providing suitable fencing or railing whose minimum height shall be 90 cm (3feet).

Safe means of access shall be provided to all working platforms and other working places. Every ladder shall be securely fixed. No portable single ladder shall be over

9m. (30 feet) in length while the width between side rails in rung ladder shall in no

case be less than 29 cm. (11.5") for ladder up to and including 3m (10 feet) in length. For longer ladders this width should be increased at least 1/4" for each additional 30 cm (1 ft.) of length. Uniform step spacing shall not exceed 30cm

(12"). Adequate precautions shall be taken to prevent danger from electrical equipment. No materials on any of the sites of the work shall be so stacked or placed as to cause danger or inconvenience to any person or the public. The contractor shall provide all necessary fencing and lights to protect the public from accident, and shall be bound to bear the expenses of defense of every suit, action or other proceeding at law that may be brought by any person for injury sustained owing to neglect of the above precautions and to pay any damages and cost which may be awarded in any such suit, action or proceedings to any such person or which may, with the consent of the Contractor, be paid to compensate any claim by any suchperson.

EXCAVATION AND TRENCHING

All trenches, 1.2mts.(four feet) or more in depth, shall at all times be supplied with at least one ladder for each 30m.(100 feet) in length or fraction thereof, ladder shall be extended from bottom of the trench to at least 90cm (3feet) above the surface of the ground. The side of the trenches, which are 1.5 m. (5feet) or more in depth shall be stepped back to give suitable slope or securely held by timber bracing, so as to avoid the danger or sides to collapsing. The excavated materials shall not be placed within 1.5m (5 feet) of the edges of the trench or half of the depth of the trench whichever is more.

Cutting shall be done from top to bottom. Under no circumstances undermining or undercutting shall be done.

Demolition - Before any demolition work is commenced and also during the progress of the work following precautions shall be observed:

All roads and open areas adjacent to the work site shall either be closed or suitably protected.

No electric cable or apparatus which is likely to be a source of danger or a cable or apparatus used by the operator shall remain electrically charged.

All practical steps shall be taken to prevent danger to persons employed from risk of fire or explosion or flooding. No floor, roof or other part of the building shall be overloaded with debris or materials as to render it unsafe.

All necessary personal safety equipments as considered adequate by the Engineer-in-charge should be kept available for the use of persons employed on the site and maintained in a condition suitable for immediate use, and the contractor should take adequate steps to ensure proper use of equipment by those concerned. The following safety equipment shall be invariably provided.

Workers employed on mixing asphaltic materials, cement and lime mortars shall be provided with protective footwear and protective goggles.

Those engaged in white washing and mixing or stacking of cement bags or any materials which are injurious to the eye shall be provided with protective goggles.

Those engaged in welding works shall be provided with welders protective eye shields.

Stone breakers shall be provided with protective goggles and protective clothing and seated at sufficiently safe interval.

When workers are employed for works in sewers and manholes, which are in active use, the Contractors shall ensure that the manhole covers are opened and ventilated at least for an hour before the workers are allowed to get into the manholes, and the manholes so opened shall be cordoned off with suitable railing and provided with warning signals or boards to prevent accident to the public. In addition, the contractor shall ensure that the following safety measures are adhered to:

Entry for workers into the sewer line shall not be allowed except under supervision of the JE or any other higher officer.

At least 5 to 6 manholes upstream and downstream should be kept open for at least 2 to 3 hours before any man is allowed to enter into the manholes for working inside.

Before entry, presence of Toxic gases should be tested by inserting wet lead acetate paper which changes color in the presence of such gases and gives indication of their presence.

Presence of Oxygen should be verified by lowering a detector lamp into the manhole. In case, no Oxygen is found inside the sewer line, workers should be sent only with Oxygen kit.

Safety belt with rope should be provided to the workers. While working inside the manholes such rope should be handled by two men standing outside to enable him to be pulled out during emergency.

The area should be barricaded or cordoned off by suitable means to avoid mishaps of any kind. Proper warning signs should be displayed for the safety of the public whenever cleaning works are undertaken during night or day.

No smoking or open flames shall be allowed near the blocked manhole being cleaned.

The malba obtained on account of cleaning of blocked manholes and sewer lines should be immediately removed to avoid accidents on account of slippery nature of the malba.

Workers should not be allowed to work inside the manhole continuously. He should be given rest intermittently. The Engineer-In-charge may decide the time up to which a worker may be allowed to work continuously inside themanhole.

Gas masks with Oxygen Cylinder should be kept at site for use in emergency.

Air-blowers should be used for flow of fresh air through the manholes. Whenever called for, portable air-blowers are recommended for ventilating the manholes. The Motors for these shall be vapour proof and of totally enclosed type. Non sparking gas engines also could be used but they should be placed at-least 2 metres away from the opening and on the leeward side protected from wind so that they will not be a source of friction on any inflammable gas that might be present. The workers engaged for cleaning the manholes / sewers should be properly trained before allowing to work in the manhole.

The workers shall be provided with Gumboots or non sparking shoes, bump helmets and gloves non sparking tools, safety lights and gas masks and portable air blowers (when necessary). They must be supplied with barrier cream for anointing the limbs before working inside the sewerlines.

Workmen descending a manhole shall try each ladder step or rung carefully before putting his full weight on it to guard against insecure fastening due to corrosion of the rung fixed to manhole well.

If a man has received a physical injury, he should be brought out of the sewer immediately and adequate medical aid should be provided to him.

The extent to which these precautions are to be taken depend on individual situation but the decision of the Engineer-In-charge regarding the steps to be taken in this regard in an individual case will be final.

The Contractor shall not employ men and women below the age of 18 years on the work of painting with products containing lead in any form wherever men above the age of 18 are employed on the work of lead painting the following precautions should be taken.No paint containing lead or lead products shall be used except in the form of paste or readymade paint.

Suitable face masks should be supplied for use by the workers when paint is applied in the form of spray or a surface having lead paint is dry rubbed and scrapped.

Overalls shall be supplied by the Contractor to the workmen and adequate facilities shall be provided to enable the working painters to wash during the cessation ofwork.

a) White lead, sulphate or lead work products containing those pigments shall not be used in painting operation except in the form of paste or of paints readyfor use.Measures shall be taken whenever required in order to prevent danger arising from the application of paint in the form of spray. Measures shall be taken, whenever practicable to prevent danger arising out of dust caused by dry rubbing down and scrapping.

b) Adequate facilities shall be provided to enable working painter to wash during and on cessation of work. Suitable arrangements shall be made prevent clothing put off during working hours being spoiled by paintingmaterials.

c) Cases of lead poisoning and of suspected lead poisoning shall be notified and shall be subsequently verified by a medical man appointed by the competent authorities of BSCDCL. The BSCDCL may require when necessary a medical examination of workers. Instructions with regard to the special hygienic precautions to be taken in the painting trade shall be distributed to working painters. When the work is done near any place where there is risk of drowning, all necessary equipments should be provided and kept ready for use and all necessary steps taken for prompt rescue of any person in danger and adequate provisions should be made for prompt first aid treatment for all injuries likely to be sustained during the course of the work. Use of hoisting machines and tackle including their attachment encourage and supports shall conform to the following standard of conditions.

d) These shall be of good mechanical construction, sound material and adequate strength and free from patent, defects and shall be kept in good working order. Every rope used in hoisting or lowering materials or as a means of suspension shall be of durable quality and adequate strength, and free from patent defects.

Every crane driver or hoisting appliance operator shall be properly qualified and no person under the age of 21 years should be in-charge of any hoisting machine including any scaffolding, winch or giving signals to operator. In case of every hoisting machine and of every chain ring hook, shackle swivel and pulley block used in hoisting or as means of suspension the safe working load shall be ascertained by adequate means. Every hoisting machine and all gear referred to above shall be plainly marked with the safe working load. In case of a hoisting machine having a variable safe working load, each safe working load and the conditions under which it is applicable shall be clearly indicated. No part of any machine or any gear referred to above in this clause shall be loaded beyond the safe working load except for the purpose of testing. In case of BSCDCL machines, the safe working load shall be notified by the Engineer-in-Charge. As regards Contractor's machines the Contractor shall notify the safe working load of the machine to the Engineer-in-charge whenever he brings any machinery to site of work and get verified by the Engineer-in-Charge.

Motors gearing, transmission electric wiring and other dangerous parts of hoisting appliances should be provided with efficient safeguard. Hoisting appliances should be provided with such means as will reduce to the minimum the risk of accidental descent of the load. Adequate precautions should be taken to reduce the minimum the risk of any part of a suspended load becoming accidentally displaced. When workers are employed on electrical installations, which are already energized, insulating mats, wearing apparel, such as gloves sleeves and boots as may be necessary be provided. The worker should not wear any rings, watches and carry keys or other materials, which are good conductors of electricity.

All scaffold, ladders, and other safety devices mentioned or described herein shall be maintained in safe condition and no scaffold ladder or equipment shall be altered or removed while it is in use. Adequate washing facilities should be provided at or near places of work.

These safety provisions should be brought to the notice of all concerned by display on a notice board at a prominent place of work spot. The person responsible for compliance of the safety codes shall be named therein by the contractor. To ensure effective enforcement of the rules and regulations relating to safety precautions the arrangements made by the Contractor shall be open to inspection by BSCDCL Official or their representatives. Notwithstanding the above Clauses from (i) to (xiv) there is nothing in these to exempt the contractor from the operations of any other Act or Rule in force in the Republic of India.

SECTION-5

FORMS AND FORMATS

ACCEPTANCE OF TENDER CONDITIONS

From: (On the letter head of the company by the authorized officer having power of attorney)

BSCDCL,

.....

Sub: Name of the work & NIT No.:

Sir,

This has reference to above referred tender. I/We are pleased to submit our tender for the above work and I/We hereby unconditionally accept the tender conditions and tender documents in its entirety for the above work.

I/we are eligible to submit the tender for the subject tender and I/We are in possession of all the documents required.

I/We have viewed and read the terms and conditions of this GCC/SCC carefully. I/We have downloaded the following documents forming part of the tenderdocument:

- a. Notice Inviting Tender(pg.....to....pg-)
- b. Instructions to Bidder (ITB) & General conditions of Contract(pg.....to....pg-)
- c. Technical Specifications (pg.....to....pg-)
- d. Bill of Quantities (BOQ)-(pg.....to....pg-)
- e. Tender Drawings(pg.....to....pg-)
- f. Acceptance of Tender Conditions (AnnexureM)
- g. Corrigendum ,if any(pg.....to....pg-)

I/we have uploaded the mandatory scanned documents such as cost of tender document, EMD, e-Tender Processing Fee and other documents as per Notice Inviting e-tender AND I/We agree to pay the cost of tender document, EMD, e- Tender Processing Fee (only receipt/proof of online payment) and other documents in physical form in the form and manner as described in NIT/ITT.

Should this tender be accepted, I/We agree to abide by and fulfill all terms and conditions referred to above and as contained in tender documents elsewhere and in default thereof, to forfeit and pay BSCDCL, or its successors or its authorized nominees such sums of money as are stipulated in the notice inviting tenders and tender documents.

If I/we fail to commence the work within 10 days of the date of issue of Letter of Award and/or I/we fail to sign the agreement as per Contract and/or I/we fail to submit performance guarantee as per of Clauses of Contract, I/we agree that BSCDCL shall, without prejudice to any other right or remedy, be at liberty to cancel the Letter of Award and to forfeit the said earnest money as specifiedabove.

Dated

Your faithfully,
(Signature of the Bidder
withRubber stamp)

FORM XXV

DETAILS OF THE BALANCE WORK IN HANDASON_____

(UPTO THE PRECEDING MONTH OF SUBMISSION OF BID) WITHBSCDCL

(To be submitted in Envelop-1)

S. No	Name of the Unit/Zone/SBG/R G B	Contract Value	Date of start as per LOI/ Contract	Date of completion as per LOI / Contract	Work done up to the preceding month of submissionof bid	Balance value of work

Note: The bidder shall also include the value of all such works which are awarded to bidder but yet not started up to the preceding month of submission of bid.

FORM XXVIAFFIDAVIT

Appendix –“0”

(To be submitted by bidder on non-judicial stamp paper of Rs. 100/- (Rupees Hundred only) duly attached by Notary Public)

(To be submitted in Envelop-1)

Affidavit of Mr.S/o R/o

.....

I, the deponent above named do hereby solemnly affirm and declare as under:

That I am the Proprietor/Authorized signatory of M/s.....Having its Head Office/Regd. Office at

.....

That the information/documents/Experience certificates submitted by M/s..... along with the tender for (NAME OF WORK).....

To BSCDCL Ltd. are genuine and true and nothing has been concealed.

I shall have no objection in case BSCDCL verifies them from issuing authority(ies). I shall also have no objection in providing the original copy of the document(s), in case BSCDCL demand so for verification.

I hereby confirm that in case, any document, information & / or certificate submitted by me found to be incorrect / false / fabricated, BSCDCL at its discretion may disqualify / reject / terminate the bid/contract and also forfeit the EMD / All dues.

I shall have no objection in case BSCDCL verifies any or all Bank Guarantee(s) under any of the clause(s) of Contract including those issued towards EMD and Performance Guarantee from the Zonal Branch /office issuing Bank and I/We shall have no right or claim on my submitted EMD before BSCDCL receives saidverification.

That the Bank Guarantee issued against the EMD issued by (name and address of theBank) is genuine and if found at any stage to be incorrect / false / fabricated, BSCDCLshall reject my bid, cancel pre-qualification and debar me from participating in any future tender for three years.

I,,the Proprietor / Authorised signatoryof

M/s..... do hereby confirm that the contents of the above Affidavit are true to my knowledge and nothing has been concealed there from..... and that no part of it isfalse.

Verified at this..... day of

DEPONENT

ATTESTED BY (NOTARY PUBLIC)

APPLICATION FOR EXTENSION OF TIME

(To be completed by the Contractor)

P A R T –I

Name of Contractor

Name of the work as given in the Agreement

Agreement No.

Estimated amount put to tender

Date of commencement work as per agreement

Period allowed for completion of work as per agreement

Date of completion stipulated as per agreement

Period for which extension of time has
been give previously

Extension granted

First extension vide Engineer-in-charge letter No.....date Months Days

2nd extension vide Engineer-in-charge letter No.....date Months Days

3rd extension vide Engineer-in-charge letter No.....date Months Days

4th extension vide engineer-in-charge letter No.....date Months Days

Total extension previously given

Reasons for which extension have been previously given (copies of the previous application should be attached)

Period for which extension is applied for:

Hindrances on account of which extension is applied for with dates on which hindrances occurred, and the period for which these are likely to last.

Serial No.

Nature of hindrance

Date of Occurrence

Period for which it is likely to last Period for which extension required for this particular hindrance.
Over lapping period, if any, with reference to item Net extension applied for Remarks, if any

Total period for which extension is now applied for on account of hindrances mentioned above.....
Month/ days.

Extension of time required for extra work.

Details of extra work and on the amount involved:

Total value of extra work

Proportionate period of extension of time based on estimated amount put to tender on account
of extra work.

Total extension of time required for 11 & 12

Submitted to the Engineer-in-Charges office.

SIGNATURE OF CONTRACTOR

DATE

**APPLICATION FOR EXTENSION OF
TIME**

(PART – II)

Date of receipt of application from Contractor for the work in the Engineer-in-charge office.

Acknowledgement issued by Engineer-in-charge vide his letter No. dated

Engineer-in-charge remarks regarding hindrances mentioned by the Contractor.

Serial No.

Nature of hindrance

Date of occurrence of hindrance

Period for which hindrance, is likely to last

Extension of time period applied for by the contractor

Over lapping period, if any, giving reference to items which over lap

Net period for which extension is recommended. Remarks as to why the hindrance occurred and justification for extension recommended.

Engineer-in-charge recommendations.

The present progress of the work should be stated and whether the work is likely to be completed by the date up to which extension has been applied for. If extension of time is not recommended, what compensation is proposed to be levied under the agreement.

SIGNATURE OF ENGINEER-IN-CHARGE

**PROFORMA FOR EXTENSION
OF TIME P A R T -III**

To NAME

ADDRESS OF THE CONTRACTOR SUBJECT:

Dear Sir(s)

Reference your letter No _____ dated _____, in connection with the grant of extension of time for completion of the work.....

The date of completion for the above mentioned work, is as stipulated in the agreement, dated

Extension of time for completion of the above mentioned work is granted upto _____, without prejudice to the right of the BSCDCL to recover compensation for delay in accordance with the provision made in Clause of the said agreement dated the ___/___/_. It is also clearly understood that the BSCDCL shall

not consider any revision in contract price or any other compensation whatsoever due to grant of this extension.

Provided that notwithstanding the extension hereby granted, time is and shall still continue to be the essence of the said agreement.

Yours faithfully,

FOR Bhopal Smart City Development Corporation Ltd.

PROFORMA OF BANK GUARANTEE IN LIEU OF E M D (TENDER BOND)

(Judicial Stamp paper of appropriate value as per stamp Act-of respective state)

In consideration of Bhopal Smart City Development Corporation Limited, having its Registered Office at, Near Natraj Petrol Pump Sector A, Berkheda (hereinafter called "BSCDCL" which expression shall unless repugnant to the subject or context include its successors and assigns) having issued Notice Inviting Tender No.....and

M/s..... having its Registered Head Office at..... (hereinafter called the "BIDDER") is to participate in the said tender for.....

Whereas BSCDCL, as a special case, has agreed to accept an irrevocable and unconditional Tender Bond Guarantee for an amount of Rs..... valid upto.....from the Bidder in lieu of Cash Deposit of Rs..... required to be made by the Bidder, as a condition precedent for participation in the said tender.

We the (hereinafter called the "BANK") having its Registered, Office at..... and branch office at..... do hereby unconditionally and irrevocably undertake to pay immediately on demand in writing and without demur/protest any amount but not exceeding Rs Any such demand made by BSCDCL shall be conclusive and binding on us irrespective of any dispute or differences that may be raised by the Bidder. Any change in the constitution of the Bidder or the Bank shall not discharge our liability under the guarantee.

We, the..... Bank, lastly undertake not to revoke this guarantee during its currency without the prior consent of BSCDCL in writing and this guarantee shall remain valid upto.....Unless a claim is made within three months from the date of expiry i.e.

..... (three months after the date of expiry), we shall be relieved of our liability under this guarantee thereafter.

FOR AND ON BEHALF OF BANK

PLACE :

DATED :

WITNESS. 1.

PROFORMA OF BANK GUARANTEE (PERFORMANCE)

(Judicial Stamp paper of appropriate value as per stamp Act-of respective state)

Whereas the Bhopal Smart City Development Corporation Limited, having its Registered Office at BSCDCL Near Natraj Petrol Pump Sector A, Berkheda, Bhopal (hereinafter called "BSCDCL" which expression shall include its successors and assigns) having awarded a work order/contract / supplyorderNo. _____ dated _____ (hereinafter called the contract) to M/s.....

..... (hereinaftercalled

thecontractor/supplier)atatotalpriceofRs..... subjecttothe terms and conditions contained in thecontract.

WHEREAS, the terms and conditions of the contract require the contractor to furnish a

Rs.... (Rupees.....

bank guarantee for ..) being % of the

total value of thecontractfor proper executionand duefulfillment of the terms and conditionscontainedin the contract.

We,theBank,(hereinafter calledthe "Bank")doherebyunconditionallyandBSCDCL irrevocably undertake to pay to immediately on demandin writing andwithout protest/or demur all moneypayable by the contractor/supplier to BSCDCL in connection with the execution/supply of and performance of the works/equipment, inclusive of any loss, damages, charges, expenses and costs caused to or suffered byorwhich would be caused to or suffered by BSCDCL by reason of any breachby the contractor/supplier of any of the terms andconditionscontained in the contract as specified in the notice of demand made byBSCDCLto the bank. Any such demand made by BSCDCL on the bank shall be conclusive evidence of the amount due and payable by the bank under this guarantee. However, the Bank's liability underthisguarantee,shall belimitedtoRs.....

intheaggregateandthebankherebyagreestoth

efollowingtermsandconditions:-

(i) This guarantee shall be acontinuing guarantee and irrevocable for all claims of BSCDCL as specified above andshallbe valid during the period specified for theperformanceof the contract including the period of maintenance/warranty i.e. up to.....

(ii) We,thesaid bank further agree with BSCDCL that shallhave the fullest liberty without our consent and without affecting in any manner our obligations and liabilitieshereunderto vary any of the terms and conditions of thesaidcontract or to extendtimeforperformanceofcontractbythecontractor

from time to time or to postpone for any time or from time totimeany of the powers exercisable by

BSCDCL against the contractor/supplier under the contract and forbear or enforce any of the terms and conditions relating to the said contract and we shall not be relieved from our liability by reason of any such variations or extension being granted to the contractor or for any forbearance, act or omission on the part of BSCDCL or any indulgence by BSCDCL to the contractor or by any such matter or thing whatsoever, which under the law relating to the sureties would, but for this provision, have effect of so relieving us.

This guarantee/undertaking shall be in addition to any other guarantee or security whatsoever BSCDCL may now or at any time have in relation to the

performance of the works/equipment and the company shall have full re-course to or enforce this security in performance to any other security or guarantee which the BSCDCL may have or obtained and there shall be no forbearance on the part of the company in enforcing or requiring enforcement of any other security which shall have the effect of releasing the Bank from its full liability. It shall not be necessary for BSCDCL to proceed against the said contractor/supplier before proceeding against the Bank.

This guarantee/ undertaking shall not be determined or affected by the liquidation or winding up, dissolution or change of constitution or insolvency of the supplier/ contractor, but shall in all respects and for all purposes be binding and operative until payment of all moneys payable to BSCDCL in terms thereof are paid by the Bank.

The Bank hereby waives all rights at any time inconsistent with the terms of this Guarantee and the obligations of the bank in terms hereof, shall not be otherwise effected or suspended by reasons of any dispute or disputes having been raised by the supplier/contractor (whether or not pending before any Arbitrator, Tribunal or Court) or any denial of liability by the supplier/contractor stopping or preventing or purporting to stop or prevent any payment by the Bank to BSCDCL in terms hereof.

We, the said Bank, lastly undertake not to revoke this guarantee during its currency except with the previous consent of BSCDCL in writing. Unless a claim is made in writing within three months from the date of expiry of this guarantee i.e.....

(three months after the date of expiry) we shall be relieved this guarantee thereafter from all liabilities under

Sign this day ofat

For and on behalf of Bank

WITNESS. 1.

2.

PROFORMA OF BANK GUARANTEE (FOR MOBILIZATION ADVANCE)

(Judicial Stamp paper of appropriate value as per stamp Act-of respective state)

Bhopal Smart City Development Corporation Limited, Near Natraj Petrol Pump, Sector A, Berkheda, Bhopal, Madhya Pradesh 4620231.0 In consideration of the Bhopal Smart City Development Corporation Limited, having its Registered Office at BSCDCL, Near Natraj Petrol Pump, Sector A, Berkheda, Bhopal (hereinafter called "BSCDCL" which expression shall unless repugnant to the subject or context include his successor and assigns) having agreed under the terms and conditions of Contract No..... dated..... made between..... and BSCDCL in connection with..... (hereinafter called "the said contract") to make at the request of the Contractor a Mobilization Advance of Rs..... for utilizing it for the purpose of the Contract on his furnishing a guarantee acceptable to BSCDCL, we the

..... Bank Ltd., (hereinafter referred to the "the said Bank") and having our registered office at..... do hereby guarantee the due recovery by BSCDCL of the said advance as provided according to the terms and conditions of the Contract. We..... do hereby undertake to pay the amount due and payable under this Guarantee without any demur, merely on a demand from BSCDCL stating that the amount claimed is due to BSCDCL under the said Agreement. Any such demand made on the..... shall be conclusive as regards the amount due and payable by the..... under this guarantee and..... agree that the liability of the to pay BSCDCL the amount so demanded shall be absolute and unconditional notwithstanding any dispute or disputes raised by the Contractor and notwithstanding any legal proceeding pending in any court or Tribunal relating thereto. However, our liability under this Guarantee shall be restricted to an amount not exceeding Rs..... We Bank further agree that BSCDCL shall be the sole judge of and as to whether the amount claimed has fallen due to BSCDCL under the said agreement or whether the said Contractor has not utilized the said advance or any part thereof for the purpose of the Contract and the extent of loss or damage caused to or suffered by BSCDCL on account of the said advance together with interest not being recovered in full and the decision of BSCDCL that the amount has fallen due from contractor or the said Contractor has not utilized the said advance or any part thereto for the purpose of the contract and as to the amount or amounts of loss or damage caused to or suffered by BSCDCL shall be final and binding on us.

We, the said Bank, further agree that the Guarantee herein contained shall remain in full force and effect till the said advance has been fully recovered and its claims satisfied or discharged and till BSCDCL certify that the said advance has been fully recovered from the said Contractor, and accordingly discharges this Guarantee subject, however, that BSCDCL shall have no claims under this Guarantee after the said advance has been fully recovered, unless a notice of the claims under this Guarantee has been served on the Bank before the expiry of the said Bank Guarantee in which case the same shall be enforceable against the Bank.

BSCDCL shall have the fullest liberty without affecting in any way the liability of the Bank under this Guarantee or indemnity from time to time to vary any of the terms and conditions of the said Contract or the advance or to extend time of performance by the said Contractor or to postpone for any time and from time to time of the powers exercisable by it against the said Contractor and either to enforce or forbear from enforcing any of terms and conditions governing the said Contract or the advance or securities available to BSCDCL and the said Bank shall not be released from its liability under these presents by any exercise by BSCDCL of the liberty with reference to the matters aforesaid or by reasons of time being given to the said Contractor or any other forbearance, act or mission on the part of BSCDCL or any indulgence by BSCDCL to the said Contractor or of any other matter or thing whatsoever which under the law relating to sureties would but for this provision have the effect of so releasing the bank from its such liability. 5.0 It shall not be necessary for BSCDCL to proceed against the Contractor before proceeding against the Bank and the Guarantee herein contained shall be enforceable against the Bank notwithstanding any security which BSCDCL may have obtained or obtain from the Contractor or shall at the time when proceedings are taken against the Bank hereunder be outstanding or unrealized.

We, the said Bank, lastly undertake not to revoke this Guarantee during its currency except with the previous consent of BSCDCL in writing and agree that any change in the constitution of the said Contractor or the said Bank shall not discharge our liability hereunder.

Dated thisday of.....

For and on behalf of Bank

(NAME AND DESIGNATION)

Dated:

PROFORMA OF BANK GUARANTEE

(IN LIEU OF SECURITY DEPOSIT)

(Judicial Stamp paper of appropriate value as per stamp Act-of respective state)

Bhopal Smart City Development Corporation Ltd., Near
Natraj Petrol Pump, Sector A, Berkheda, Bhopal

In consideration of the Bhopal Smart City Development Corporation Ltd., having its

Registered Office at Near Natraj Petrol Pump Sector A, Berkheda (hereinafter called "BSCDCL") which expression shall include its successors and assigns having awarded to M/s..... (hereinafter called "the Supplier/Contractor") which expression shall wherever the subject or context so permits includes its successors and assigns) a Contract in terms inter-alia of BSCDCL's letter No..... dated..... and the Contract/Purchase Conditions of BSCDCL and upon the condition of the Supplier/Contractor furnishing Security for the performance of the Supplier's obligations and /or discharge of the contractor's/supplier's liability under and/or in connection with the said supply contract upto a sum of Rs..... (Rupees.....only)

We,..... ((hereinafter called "The Bank") which expression shall include its successors and assigns) hereby undertake and guarantee payment to BSCDCL forthwith on the same day on demand in writing and without protest or demur of any and all moneys payable by the supplier/contractor to BSCDCL under, in respect or in connection with the said contract inclusive of all the losses, damages, costs, charges and expenses and other moneys payable in respect of the above as specified in any notice of demand made by BSCDCL to the Bank with reference to this guarantee upto and aggregate limit of Rs.....(Rupees.....only) and the bank hereby agree with BSCDCL that:

This Guarantee shall be continuing guarantee and shall remain valid and irrevocable for all claims of BSCDCL and liabilities of Supplier/Contractor arising upto and

until midnight of.....

This Guarantee shall be in addition to any other Guarantee or Security whatsoever that BSCDCL now or at any time have in relation to the Supplier's obligations/liabilities under and/or in connection with the said supply/contract, and BSCDCL shall have full authority to take recourse or to enforce this Security in

preference to any other Guarantee or Security which BSCDCL may have or obtain and no forbearance on the part of BSCDCL in enforcing or requiring enforcement of any other Security shall have the effect of releasing the Bank from its liability hereunder.

BSCDCL shall be at liberty without reference to the Bank and without affecting the full liability of the Bank hereunder to take any other security in respect of the Supplier's/Contractor's obligations and/ or liabilities under or in connection with the said supply/contract or to grant time and / or indulgence to the supplier / contractor or to increase or otherwise vary the prices or the total contract value or to release or to forbear from enforcement of all or any of the conditions under the said supply / contract and / or the remedies of BSCDCL under any other security/securities now or hereafter held by BSCDCL and no such dealings, increase(s) or other indulgence(s) or arrangement(s) with the supplier / contractor or releasing or forbearance whatsoever shall have the effect of releasing the Bank from its full liability to BSCDCL hereunder or prejudicing rights of BSCDCL against the Bank. This Guarantee shall not be determined or affected by the liquidation or winding up, dissolution or change of constitution or insolvency of the supplier / contractor but shall in all respects and for all purposes be binding and operative until payment of all moneys payable to BSCDCL in terms thereof.

The Bank hereby waives all rights at any time inconsistent with the terms of this Guarantee and the obligations of the Bank in terms hereof shall not be otherwise affected or suspended by reason of any dispute or disputes having been raised by the supplier /contractor (whether or not pending before any Arbitrator, Tribunal or Court) or any denial or liability by the supplier/ contractor stopping/ preventing or purporting to stop or prevent any payment by the Bank to BSCDCL in terms thereof.

The amount stated in any notice of demand addressed by BSCDCL to the Guarantor as liable to be paid to BSCDCL by the supplier/contractor or as suffered or incurred by BSCDCL on account of any losses or damages, costs, charges and / or expenses shall as between the Bank and BSCDCL be conclusive of the amount so liable to be paid to BSCDCL or suffered or incurred by BSCDCL as the case may be and payable by the Guarantor to BSCDCL in terms hereof subject to a maximum of Rs (Rupees only),

Unless demand or claim under this Guarantee is made on the Guarantor in writing within three months from the date of expiry of the Guarantee i.e upto the

Guarantor shall be discharged from all liabilities under this Guarantee there under.

Notwithstanding anything contained herein before our liability under this guarantee is restricted to Rs (Rupeesonly). This guarantee will expire on..... Any claim under this Guarantee must be received by us within three months from the date of expiry i.e..... (date, three months after the expiry

date) and if no such claim has been received by us by that date all your rights under this guarantee will cease.

For and on behalf of the Bank

Place Date

WITNESS:

1.

2.

PROFORMA OF BANK GUARANTEE
(FOR MOBILIZATION ADVANCE WITH INTEREST BEARING)

(Judicial Stamp per Stamp Act - paper of appropriate value as respective state)

Bhopal Smart City Development Corporation Limited,
Bhopal, Pin- 462023

In consideration of the Bhopal Smart City Development Corporation Limited., having its Registered Office at Bhopal -462023 (hereinafter called "BSCDCL" which expression shall unless repugnant to the subject: or context Include his successor and assigns) having agreed under the terms and conditions of Contract No. dated made between (name of the contractor) and BSCDCL in connection with (name of work) (hereinafter called "the said contract") to make at the request of the Contractor a Mobilization Advance of Rs. carrying interest @ ... % p.a. for utilizing it for the purpose of the Contract on his furnishing a guarantee acceptable to BSCDCL, we the Bank (hereinafter referred to the "the said Bank") and having our registered office at do hereby guarantee the due recovery by BSCDCL of the said advance alongwith interest as provided according to the terms and conditions of the contract. We...

do hereby undertake to pay the amount due and payable under this Guarantee without any demur, merely, on a demand from BSCDCL stating that the amount claimed is due to BSCDCL under the said Agreement. Any such demand made on the said bank shall be conclusive as regards the amount due and payable by the said contractor under this guarantee and agree that the liability of the said bank to pay BSCDCL the amount so demanded shall be absolute and unconditional notwithstanding any dispute or disputes raised by the Contractor and notwithstanding any legal proceeding pending in any court or Tribunal relating thereto. However,ourliabilityunderthisGuaranteeshallberestrictedtoanamountnotexceedingRs

..... inclusive of interest @% p.a.

We the said bank further agree that BSCDCL shall be the sole judge of and as to whether the amount claimed has fallen due to BSCDCL under the said agreement or whether the said Contractor has not utilized the said advance or any part thereof for the purpose of the Contract and the extent of loss or damage caused to or suffered by BSCDCL on account of the said advance together with interest not being recovered in full and the decision of BSCDCL that the amount has fallen due from' contractor or the said Contractor has not utilized the said advance or any part thereto for the purpose of the contract and as to the amount or amounts of loss or damage caused to or suffered by BSCDCL shall be final and binding on us.

We, the said Bank, further agree that the Guarantee herein contained shall remain

in full force and effect till the said advance has been fully recovered and its claims satisfied or discharged and till BSCDCL certify Contractor, and accordingly discharges this Guarantee subject, however, that BSCDCL shall have no claims under this Guarantee unless a notice of the claims under this Guarantee has been served on the Bank before the expiry of the said Bank Guarantee in which case the same shall be enforceable against theBank.

BSCDCL shall have the fullest liberty without affecting in any way the liability of the Bank under this Guarantee or indemnity from time to time to vary any of the terms and

conditions of the said Contract or the advance or to extend time of performance by the said Contractor or to postpone for any time and from time to time of the powers exercisable by it against the said Contractor and either to enforce or forbear from enforcing any of terms and conditions

governing the said Contract or the advance or securities available to BSCDCL and the said Bank shall

not be released from its liability under these presents by any exercise by BSCDCL of the liberty with reference to the matters aforesaid or by reasons of time being given to the said Contractor or any other forbearance, act or omission on the part of BSCDCL or any indulgence by BSCDCL to the said Contractor or of any other matter or thing whatsoever which under the law relating to sureties would but for this provision have the effect of so releasing the bank from its such liability.

It shall not be necessary for BSCDCL to proceed against the Contractor before proceeding against the Bank and Guarantee herein contained shall be enforceable against the Bank notwithstanding any security which BSCDCL may have obtained or obtain from the Contractor or shall at the time when proceedings are taken against the Bank hereunder be outstanding or unrealized.

We, the said Bank, lastly undertake not to revoke this Guarantee during its currency except with the previous consent of BSCDCL in writing and agree that any change in the constitution of the said Contractor or the said Bank shall not discharge our liability hereunder.

Dated this..... day of..... Place:

Date:

Witness:

1.

PROFORMA OF

INDENTURE FOR SECURED ADVANCE OR CREDIT

THIS INDENTURE made this day of _____ Between (hereinafter called the contractor) which expression shall where the Context as admits or implies be deemed to include his executor/administrators and assign of the one part and National Buildings Construction Corporation Ltd., having its Registered Office at BSCDCL, Bhopal (hereinafter called the Engineer) which expression shall where the context so admits or implies be deemed to include its successors and assign of the other part.

Whereas by an agreement dated (hereinafter called the said agreement). The Contractor has agreed to construct.....

And whereas the Contractor has applied to the Engineer that he may be or be given credited for materials brought by him to the site of the work subject to the said agreement for use in construction of the work.

NOW THIS INDENTURE WITNESSETH that in pursuance of the said agreement and in consideration of the sum of Rs. _____ (Rupees _____ only) paid to the contractor by the Engineer. The receipt where the Contractor hereby acknowledges and of such advance or credited (if any) as may be made to him as aforesaid the Contractor hereby covenants and agrees with The Engineer and declares as follows:

That all sums given as advance or credit by The Engineer to the Contractor as aforesaid shall be employed by the Constructor in or toward the execution of the said works and for no other purpose whatsoever.

That the material for which the advance or credit is given are offered to and accepted by The Engineer as security and are absolutely the Contractor's own property and free from encumbrances of any kind the Contractor will not make any application for or receives further advance or credit on the security or material which are not absolutely his own property and free from encumbrances of any kind and the Contractor shall indemnify The Engineer against any claims to any material in respect of which advance or credit has been made to him as aforesaid.

That the said material and all other material on the security of which any further advance or advances or credit may be given as aforesaid (hereinafter called the said materials) shall be used by the Contractor solely in the execution of the said works in accordance with the direction of the Engineer and in terms of said agreement.

That the Contractor shall make at his own cost all necessary and adequate arrangement for the proper safe custody and protection against all risks of the said material and that until used in the construction as aforesaid the material shall remain at the site of the said works in Contractor's custody and on his responsibility and shall at all times be open to inspection by The Engineer. In the events of the materials or any part thereof being stolen, destroyed or damaged or becoming deteriorated in greater degree than in due to reasonable use and wear thereof the Contractor will replace the same with other materials of like quality of repair and make good the same as required by The Engineer. That said material shall not on any account be removed from the site of work except with the written permission of The Engineer.

That the advance shall be repayable in full when or before Contractor receives payment from The Engineer of the price payable to him for the said work under the term and provisions of the said agreement. Provided that if any intermediate payments are made to the Contractor on account of work done then on the occasion of each payment

The Engineer will be at liberty to make a recovery from the Contractor's bill from such payments by deducting there from the value of the said materials than actually used in the contraction and in respect of which recovery has not been made previously. The value of this purpose being determined in respect of each description of materials at the rates at which the amounts of the advance as made under these presents was calculated.

That if the Contractor shall at any time make at any default in the performance of observance in respect of any of the terms and provisions of the said agreement or of that provisions the total amount of the advance or advances that may still be owing to The Engineer, shall immediately on the happening of such default be repayable by the Contractor to The Engineer together with interest thereon at 12% p.a. from the date of respective dated to such advance or advances to the date of payment and with all costs. Damages and expenses incurred by The Engineer in or for recovery hereof or the Contractor hereby covenants and agrees with The Engineer to repay and pay the same respective to him accordingly.

That the Contractor hereby charges all the said materials with the repayment to The Engineer of all sums advances or credit as aforesaid and all costs. Charges, damages and expenses payable under these presents PROVIDED ALWAYS it is hereby agreed and declared that notwithstanding anything in the said agreement and without prejudice to the powers contained therein if and wherever the covenant for payment and repayment herein before contained shall be become enforceable and the money owing shall not be paid in accordance therewith. The Engineer may at any time thereafter adopt all or any of the following courses he may deem best:

Seize the utilize the said material or any part thereof in the completion of the said works in accordance with the provision in that behalf contained in the said agreement debating the Contractor with the actual cost of effecting such completion and the amount due in respect of advance or credit under these presents and crediting the Contractor with value of work done as if he has carried it out in accordance with the said agreement and the rates thereby provided if the balance is against the Contractor is to pay the same to the engineer on demand.

Remove and sell by public action the seized materials or any part thereof and out of the money arising from the sale repay the engineer under these presents and pay over the surplus (if any) to the Contractor.

Deduct all or any part of the moneys owing from any sums due to the contractor under said agreement..Expect in the event of such default on the part of contractor as aforesaid, interest or the said advance shall not be payable.

That in the event of conflict between the provisions of these presents and the said agreements, the provision of these presents shall prevail and in the event of any dispute or difference arising over the construction or effect of these presents, the settlement of which has not been hereinbefore expressly provided for the same shall so far as is lawful be subject to jurisdiction of BHOPAL court only.

IN WITNESS whereof the said the engineer and the contractor hereunto set their respective hands and seals the day year first above written.

Signed Sealed and delivered by

Contractor

The Engineers

AGREEMENT FORM

This agreement made this day of (Month) (Year), between the **Bhopal Smart City Development Corporation Limited (BSCDCL)**, a company incorporated under the Companies Act, 1956 having its Registered Office at BSCDCL, Bhopal 462023 (hereinafter referred to as the “BSCDCL” which expression shall include its administrators, successors, executors and assigns) of the one part and **M/s (NAME OF CONTRACTOR)** (hereinafter referred to as the „Contractor“ which expression shall unless the context requires otherwise include its administrators, successors, executors and permitted assigns) of the otherpart.

WHEREAS, BSCDCL, has desirous of construction of **(NAME OF WORK)** (hereinafter referred to as the “PROJECT”) on behalf of the **(NAME OF OWNER/MINISTRY)** (hereinafter referred to as “OWNER”), had invited tenders as per Tender documents vide NIT No..

AND WHEREAS **(NAME OF CONTRACTOR)** had participated in the above referred tender vide theirtenderdated_____and BSCDCL has accepted their aforesaid tender and award the contract for **(NAME OF PROJECT)** on the terms and conditions contained in its Letter of Intent No. _____and the documents referred to therein, which have been unequivocally accepted by **(NAME OF CONTRACTOR)** vide their acceptanceletterdated_____resulting into a contract.

NOW THEREFORE THIS DEED WITNESSETH AS UNDER:

ARTICLE 1.0 – AWARD OF CONTRACT

SCOPE OF WORK

BSCDCL has awarded the contract to **(NAME OF CONTRACTOR)** for the work of **(NAME OF WORK)** on the terms and conditions in its letter of intent No.

_____dated_____and the documents referred to therein. The award has taken effect from **(DATE)** i.e. the date of issue of aforesaid letter of intent. The terms and expressions used in this agreement shall have the same meanings as are assigned to them in the “Contract Documents” referred to in the succeedingArticle.

ARTICLE 2.0 – CONTRACT DOCUMENTS

The contract shall be performed strictly as per the terms and conditions stipulated herein and in the following documents attached herewith (hereinafter referred to as “Contract Documents”).

date_____and

BSCDCL Notice Inviting TendervideNo. _____
BSCDCL’s tender documents consistingof:

General Conditions of Contract (GCC) alongwith amendments/errata to GCC
(if any) issued (Volume-I).

Special Conditions of Contract including Appendices & Annexures, Volume-II.

Bill of Quantities alongwith amendments/corrigendum of schedule items, if any
(Volume-II).

(NAME OF CONTRACTOR) letterproposaldated_____ and their
subsequent communication:

Letter of Acceptance of Tender Conditions dated _____

BSCDCL's detailed Letter of Intent No. _____ dated _____ including Bill of Quantities, Agreed time schedule, Contractor's Organization Chart and list of Plant and Equipment's submitted by Contractor.

All the aforesaid contract documents referred to in Para 2.1 and 2.2 above shall form an integral part of this Agreement, in so far as the same or any part thereof conform, to the tender documents and what has been specifically agreed to by BSCDCL in its Letter of Intent. Any matter inconsistent therewith, contrary or repugnant thereto or deviations taken by the Contractor in its "TENDER" but not agreed to specifically by BSCDCL in its Letter of Intent, shall be deemed to have been withdrawn by the Contractor without any cost implication to BSCDCL. For the sake of brevity, this Agreement along with its aforesaid contract documents and Letter of Intent shall be referred to as the "Contract".

ARTICLE 3.0 – CONDITIONS & CONVENANTS

The scope of Contract, Consideration, terms of payments, advance, Performance Guarantee, taxes wherever applicable, insurance, agreed time schedule, compensation for delay and all other terms and conditions contained in BSCDCL's Letter of Intent No. _____ dated _____ are to be read in conjunction with other aforesaid contract documents. The contract shall be duly performed by the contractor strictly and faithfully in accordance with the terms of this contract.

The scope of work shall also include all such items which are not specifically mentioned in the Contract Documents but which are reasonably implied for the satisfactory completion of the entire scope of work envisaged under this contract unless otherwise specifically excluded from the scope of work in the Letter of Intent.

Contractor shall adhere to all requirements stipulated in the Contract documents.

Time is the essence of the Contract and it shall be strictly adhered to. The progress of work shall conform to agreed works schedule/contract documents and Letter of Intent.

This agreement constitutes full and complete understanding between the parties and terms of the presents. It shall supersede all prior correspondence to the extent of inconsistency or repugnancy to the terms and conditions contained in Agreement. Any modification of the Agreement shall be effected only by a written instrument signed by the authorized representative of both the parties.

The total contract price for the entire scope of this contract as detailed in Letter of Intent is Rs. _____ (Rupees _____ only), which shall be governed by the stipulations of the contract documents.

ARTICLE 4.0 – NO WAIVER OF RIGHTS

Neither the inspection by BSCDCL or the Engineer-in-Charge or Owner or any of their officials, employees or agents nor order by BSCDCL or the Engineer-in-Charge for payment of money or any payment for or acceptance of, the whole or any part of the work by BSCDCL or the Engineer-in-Charge nor any extension of time nor any possession taken by the Engineer-in-Charge shall operate as waiver of any provisions of the contract, or of any power herein reserved to BSCDCL, or any right to damage herein provided, nor shall any waiver of any breach in the contract be held to be a waiver or any other or subsequent breach.

ARTICLE 5.0 – GOVERNING LAW AND JURISDICTION

The Laws applicable to this contract shall be the laws in force in India and jurisdiction of BHOPAL Court (s) only.

Notice of Default

Notice of default given by either party to the other party under the Agreement shall be in writing and shall be deemed to have been duly and properly served upon the parties hereto, if delivered against acknowledgment due or by FAX or by registered mail duly addressed to the signatories at the address mentioned hereinabove.

IN WITNESS WHEREOF, the parties through their duly authorized representatives have executed these presents (execution whereof has been approved by the Competent Authorities of both the parties) on the day, month and year first above mentioned at BHOPAL.

For and on behalf of:

For and on behalf of:

(NAME OF CONTRACTOR) (M/s Bhopal Smart City Development Corporation)

WITNESS:

WITNESS:

1.

1.

SECTION-6

**SCOPE OF WORK
&
SPECIAL CONDITION
OF CONTRACT**

SCOPE OF WORK

The works under Contract comprises the supply and installation of modern fully underground waste collection system by using smart bins for collection of municipal solid waste at designated locations in Bhopal city other related miscellaneous works along with operation and maintenance of tendered works for period of five years on procurement and construction basis including preparation of working drawings.

Details and drawings given in Tender document is for information purpose only and successful bidder shall undertake confirmatory survey for accuracy and completeness of data. It is in scope of successful Bidder to undertake all Site surveys, investigations, Underground Utility Survey and Scanning of the roads for Geotechnical utility shifting, obtaining all required approvals from the relevant authorities, Carry out Design and Drawings for all the components of the work as per Employers requirement and submit the same to client for review and approval, Prepare Good for Construction Drawings, submit maintenance manual to client for approval before start of Maintenance period.

The successful bidder shall have to prepare and submit 'As Built Drawings' depicting the exact construction carried out on site, in soft and hard copy format. Statutory and other charges for getting various required approvals shall be in scope of Successful bidder. The Size of Bin and the maintenance work program shall be submit by the successful bidder and get approved by BSCDCL

The scope of work also includes:

Project Components-

Component 1:

- i) Supply, delivery, installation of a set of two units of Modern fully Underground Waste Collection Bins each comprising of capacity of 3 cum at a designated single location as per requirement.**
- ii) Supply, delivery, installation of single units of Modern fully Underground Waste Collection Bins each comprising of capacity of 3 cum at a designated location as per requirement.**
- iii) Supply, delivery, installation of single units of Dual Compartment Modern fully Underground Waste Collection Bins each comprising of capacity of 3 cum(2x1.5m3) at a designated location as per requirement.**

Supply and erection of national/international standard underground waste collection bins made of galvanized steel installed in reinforced cement concrete cases with a minimum 90 mm thickness, having water proof, closed construction. The Intake columns and the below container shall be lifted with a knuckle boom crane which is attached with a 2 (two)/1 (one) hook lifting and emptying device. The Height of solid waste receiver shall be min 600mm or as approved by Engineer-in-charge of BSCDCL.

All parts of container and all other steel frame are required to be steel plate with galvanized steel.

The container must be suitable for collecting municipal solid waste especially for wet/bio- degradable / organic waste and non-biodegradable waste with an opening suitable to receive the solid waste by the user / municipal worker at ward / street-level and for door-to-door collection from households and commercial establishments. The entire bin should be free from fire risk, vandalism and be safe and should provides the Space on the pillar/intake columns may be so designed that it be used for running awareness among the users / citizen for

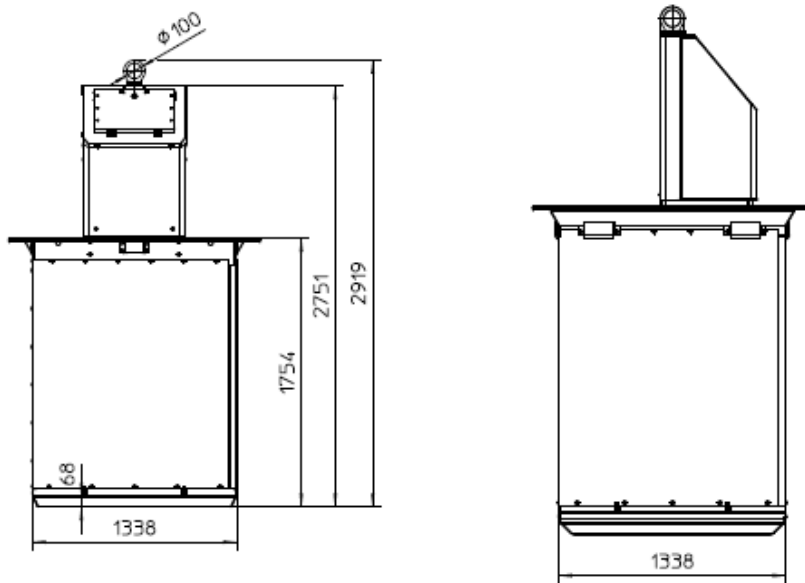

Figure 1: Details of 3cu.m. unit Fully Underground Bin

safe garbage disposal. The desired colors and logo's, are to be supplied as per the requirements of tender inviting authorities. The pillar/ intake column should have an opening facility, so that the rickshaw, hand cart puller/ sweeper/ can dispose the MSW directly to the intake pillar.

Material Specifications:

The minimum material specifications areas follows:

For the container:

- Side walls made of 2 mm galvanized MS sheet according to DIN S235JR
- Bottom frame made of 4 mm hot-dip galvanized steel sheet according to DIN S235JR
- Trap doors made of 3 mm hot-dip galvanized steel sheet according to DIN S235JR
- Intake Column is modularly build and made from galvanized steel with additional powder coating or spray painting
- Bins are manufactured according to DIN ISO 2768-1.

Stickers: The supplier shall provide separate coloured stickers on the pillars marking Biodegradable/ Wet Waste (Green), Non-biodegradable/ Dry Waste (Blue) using pictograms writings to help people clearly identify the bins for the use of depositing segregated waste/ general waste inside the bins. The pillars/intake column shall be distinctively marked for easy identification.

InstallationProcedure:

- Pit excavation
- Construction of rectangular concrete casing
- Loose filling and closing of the pit surroundings

- Tiling works and finishing
- Installation of the Modern Underground Waste collection Bin

Component 2: Civil Works

- Necessary Earth work excavation shall be carried out in all types of soil including Bituminous/ CC road /paved area cutting for seating of RCC Trough / RCC Bunker with a minimum M-30 grade mix, over 1:3:6 PCC, the RCC Trough/ RCC bunker shall be with required steel reinforcement and the edges are secured by MS angles on all four sides at the top. The RCC trough/ RCC Bunker shall be cast in-situ or precast in nature.
- A concrete platform of CC not less than 1:2:4 with 20 mm and down size jelly shall be constructed at ground level on firm ground and provided with paver blocks / anti-skid tiles to give good aesthetic appearance.
- The gap around the RCC trough/ RCC bunker shall be filled with Granular/filter media/granular soil material and the remaining debris shall be removed from the location and the location shall be kept clean and tidy.

Component 3: Bin Level sensors and its Automated Software

- The operator shall install bin levelling system on each bin and shall provide a software solution for tracking the levelling of waste filled in underground bins at various locations on real time basis. The software solution must be mobile compatible and must also provide the optimal route management solution with a provision for alerting the operator for emptying a specific bin by keying in the codes. Software should have the capabilities to generate data log as and when required. The software should be modular to be able to add or remove additional components as required and provide administrator users to the Bhopal Smart City Development Corporation Limited. The Monitoring Software must be accessed by designated officer by BSCDCL over internet & also all to be integrated at BSCDCL control command Centre.

Sr. No	Parameter	Value
	Sensor Type	Ultrasonic
	Signal distribution Technology	GPRS over GSM (Quad band – 850/900/1800 MHz) with internal SIM Card. No user accounts required.
1	Dimensions	Width x Height 90mmx67 mm
2	Standard Thread Mount	1 inch NPT
3	Container Depth max.	3.0 meters
4	Min. Measurement	15 cm
5	Temperature Rating	-30 C to +70 C (operation)
6	Battery Life	Upto 10 years
7	Protection rating	IP66

8	Shocks	100geach Axis(EN60058-2-27/F4)
9	Impact	IK10 (EN50102/F4)
10	Recycling	ROHS Compatible
11	Housing	High-density IP66 polyethylene (HDPE)
12	Communications	EGSM(850/900/1800/1900MHz)
13	CE Certification	CE0980 Articles3.1(a)(b), 3.2 (inside)
14	FCC Compliance	FCCID:UDV-0912142009007 (inside)

Component 4: Crane

Knuckle boom truck mounted Crane with remote control operation to lift the Underground Bins. The CRANE must have a minimum Lifting Capacity of 1.7 Tons from approx. 6 Meter horizontal & vertical outreach along with manual outriggers hydraulic stabilizers, including sub-frame fabrication, mounting & installation and commissioning on compactor Truck.

Crane should have remote control and manual over drives other operator can operate the crane safely. Crane shall be securely fitted between the truck cabin and compactor body with required reinforcements so that the truck chassis or the sub frame is not damaged or cracked in due course of operations.

Knuckle Boom truck mounted Crane with the following specification	Palfinger/Hyva/Hiab make or similar 9.5tm crane
Min. lifting moment	9.5 mt/93.5 kNm
Min. lifting capacity	5700 kg/55.9 kN
Min. Hydraulic outreach	12.4 meters
Min. Slewing angle	400°
Min. Stabilizer spread	3.3 m standard and 5.6 m max.
Min. Width folded	2.5 m
Min. Operating pressure	315 bar

Component 5: Compactor Truck for Collection of Municipal Solid Waste

Commissioning of Compactor Truck with company fitted PTO gear box on 16 Ton GVW Chassis (TATA/Eicher/Benz/Mahindra or similar approved by the Engineer-in-charge of BSCDCL) with cabin and hydraulically controlled compactor body for easy collection and disposal of municipal solid waste collection along with an in-built bin washing system for regular cleaning of underground bins. The compactor body must be so fabricated that it should be intended to fit a crane between the driver cabin and compactor body suitable

for emptying the underground bins through standard compactor bin lifting device. The truck used for collection of waste from smart bins to designated location provided by BSCDCL.

Construction activity and completion of the following

- a) Site clearance, earthworks, temporary works, barricading the construction site, and all ancillary works deemed necessary for the carrying out of temporary & permanent construction works.
- b) Construction of reinforced concrete bunker as per approved drawing.
- c) All other works and services ancillary or related to the full completion of the Works in accordance with the Employer's requirements.

The Contractor shall support and protect services that need not be diverted. The Contractor's responsibility for the design and build works and should take the approval from Engineer-in-charge of BSCDCL. Other government authorities / technical departments for obtaining all necessary clearances/approvals shall be done by BSCDCL.

The Contractor shall co-ordinate and interfaces his works with that of all other contractors, sub contractors, utility services, statutory authorities, etc and achieve the completion of the Works to the satisfaction of the Engineer.

The Contractor shall done Restore as previous of existing place including road surfaces, drains, concrete slabs, gratings, kerbs, pavements, turfing, railing, fence, boundary wall, etc. affected or damaged during the course of construction, to the satisfaction of the Engineer. The costs of making good all these defects shall be borne solely by the Contractor and deemed included in his Contract Sum All works specified shall include the provision of all labour, tools, equipment, material, transport and everything else necessary for the satisfactory completion of the Work by the Contractor to the satisfaction of the Engineer. No extra payment shall be done for restoration work.

DESIGN OF WORKS:

The Contractor shall carry out, and be responsible for the design of the Works, including any site surveys, subsoil investigations, materials testing, and all other things necessary for proper planning and design.

With 10 days from Award of work, the Contractor shall start submitting drawings, Construction etc. for review and approval by the Employer's Representative.

The Contractor will be fully responsible for ensuring that its designs, drawings, and construction documents satisfy all requirements for constructing Works that are complete and fully functional in all respects.

The Contractor shall prepare, and keep up-to-date, a complete set of "as-built" records of the execution of the Works, showing the exact as-built locations, sizes and details of the work as executed. These records shall be kept on the Site and two sets of such records shall be submitted to Employer.

In addition, the Contractor shall supply to the Employer's Representative as-built drawings of the Works, showing all Works as executed.

Contractor shall be responsible for Preparing Baseline Programme, upon acceptance of the Baseline Programme by the BSCDCL, the Contractor shall adhere to it strictly. The Contractor shall ensure that preparation, updating and revision of programme of works are carried out by experienced and qualified personnel.

Operation & Maintenance Requirement

During Operation & Maintenance period, it shall be the responsibility of the contractor to collect the waste from

Smart bin and deposit it to nearest Waste transfer station/waste collection point as suggested by BSCDCL. The Contractor has to provide detail process write-up of Waste collection process from smart bins including loading and unloading procedure and deposit it to nearest transfer station/ waste collection point. The movement of waste collection vehicles shall be considered 150KM per day.

Before Commencement of Operation & maintenance Period, the Contractor shall submit Operation & Maintenance manual to BSCDCL for approval. BSCDCL shall review and finalize Operation and Maintenance requirements to be carried out by the Contractor. Operation & maintenance period will commence only after getting approval to Operation & Maintenance manual from BSCDCL. During the operation and maintenance period contractor shall provide a supervisor level staff for attending to all the O& M activities during the O&M Period. All the Operation and Maintenance obligations as approved by BSCDCL shall be carried out by the Contractor.

The monthly report on the Operation and Maintenance shall be submitted to the Engineer and monthly payment for O& M as per the BOQ shall be released to the contractor based on the work carried out by him and assessment by the Engineer in charge. BSCDCL reserves the right for reduction in such payments, for any delay in attending the Maintenance obligation within the stipulated time as approved by BSCDCL.

Design and Drawings to be submitted for review and Approval

On Award of work the Contractor shall submit the design and Drawing for review and approval. Drawings mentioned in the list are indicative and for Information. Contractor shall not limit himself to the same but it is in scope of Contractor to submit all required design and drawings for review and approval as per Instruction from Engineer-In-Charge.

Sr No	Documents
1	Geotechnical investigation report
2	Topography Survey Layout
3	Civil / structural design basis report
4	Structural design (calculations) report
5	Design, Drawings, Sections for all Waste Collection bins

Sealing and Stickers:

The space on the external part above the ground of underground bin may be so designed that it'll be used for running awareness among the users/citizen for safe garbage disposal. The desired colour stickers/logo's and the awareness message shall be provided by Bhopal Smart City Development Corporation Limited. The bins shall be distinctively marked for easy identification. The marking and pictograms writings on the underground bins must be designed to help people clearly identify the bins for its use of depositing general waste in the bins.

Waste Collection Process

The waste collection process must be composed of an innovative lifting system, bilateral, automated and mono-operator devices which, are able to collect waste from various types of ground level and underground containers/bins.

The technologies being used for the waste collection process are Radio Frequency Identification (RFID), Global Position System (GPS), General Packet Radio Service (GPRS), and Geographic Information System (GIS). The collection trucks are embedded with an RFID reader which helps in retrieving all the bin information from the RFID tags/ wireless ultrasonic and infrared sensors which are also amended with a SIM card and a replaceable Lithium battery placed in each bin. These sensors use advanced ultrasonic measurement and digital signal processing techniques for better accuracy to identify the waste fill level in the bin.

The sensor can be remotely configured to read the fill levels periodically at set intervals. The sensor can also be configured to store the readings frequently and send them to the server whenever it breaches a threshold level. The live alerts in the form of SMS and emails will be sent directly from the server to the centralized system. The location of the bins is identified by GPS and the centralized system will pass this message to truck drivers to initiate the waste collection process. A mobile app/ web application for truck drivers shall also be provided where the routes and bins to pick up can be seen by the drivers. This app also has the facility to upload real-time photographs of underground bins and the exact weight cleared.

This information is regularly transferred in real time through GPRS to a database which is centrally located. A web application is designed so that the users can view the current location of the trucks individually during collection. A map server stores a digital map which displays the positions of the trucks as well as trash bin information. By using this technique, the system can come to know whether the truck has arrived to the bin location or not. The waste filling rate can be determined by the Intelligent Remote Monitoring sensor. Accordingly, waste will be collected from the bins.

SPECIAL CONDITIONS OF CONTRACT (SCC)

GENERAL-

- 1.1. The following special conditions shall be read in conjunction with General conditions of contract. If there are any provisions in these Special Conditions, which are at variance with the provisions of General Conditions of Contract, the provisions in the Special Conditions shall take precedence.
- 1.2. Where any portion of Special Conditions of Contract is repugnant to or at variance with any provision of the instructions to Bidder and General Conditions of Contract and / or the other documents forming part of the contract then unless a different intention appears the provision of the Special Conditions of Contract shall be deemed to override the provisions of the general conditions of contract and / or the other documents forming part of the contract only to the extent such repugnant/various in the special conditions of contract as are not possible of being reconciled with the provisions in the special conditions of contract as are not possible of being reconciled with the provision with instructions to Bidder or General Conditions of contract and /or the other documents from part of the contract.
- 1.3. Tentative drawing shall be according to the drawing given in the Tender document.
- 1.4. Items mentioned in the BOQ may vary or any changes is needed then it should bring to the attention of BSCDCL.
- 1.5. Tentative drawings are given by BSCDCL in tender document; if any deviations found and correction required then it should be brought to BSCDCL for rectification.
- 1.6. The items which are missing or not defined in the given BOQ in this Tender Document, then the contractor has to submit the items for approval to BSCDCL.
- 1.7. The contractor has to submit sample of the items defined in BOQ the same to be approved by BSCDCL, before use.
- 1.8. Civil and Internal wiring work should be done as per UADD/MPPWD/CPWD/MPPWD Specification. And the rates if required shall be taken from the mentioned SOR's.
- 1.9. Testing of materials shall be done from licensed laboratory or from engineering institute like MANIT/RGPV, before any commencement of work, and the same test reports shall be submitted to BSCDCL.
- 1.10. The Contractor shall have to maintain proper site documents and share the same with the Engineer-in-charge of BSCDCL as per CPWD Quality Assurance Manual.
- 1.11. The Location Layout Plan of the Underground Waste Collection Bin System shall be provided later, award of Tender, by the approval of ED, BSCDCL
- 1.12. The Space for the Monitoring Waste Collection Bin System shall be provide by BSCDCL.
- 1.13. For Operation of Collection of Garbage from Under Ground Garbage Bin, the running of Vehicle shall be 4,500KM/Month with 5 % variation of plus or minus, after variation limit it shall be adjusted accordingly.
- 1.14. The quoted rates for Sensors used in garbage bin collection shall be comprehensive for Supply, Commissioning , Installing, operations, maintenance of hardware and software both, battery replacement , Horizontal & Vertical services expansion/integration through

sensors/API for O & M Period of 5-years. No extra cost shall be paid for the same.

1.15. All the data received from the sensors will be directly transferred, processed and monitoring in/from control and command centre of BSCDCL. Solution also include landing/dash board for proper monitoring and controlling manually and automatically. The bidder solution inclusive of all manual and site operations.

1.16. Supply and Installation of Modern Underground Waste Collection System by Using Smart Bins for Collection of Municipal Solid Waste at Designated Locations in Bhopal City and other related Miscellaneous works along with Collection and Transfer of Waste during Operation and Maintenance (Include of Washing of bins, replace/repair of damage bins, provide the missing part of bins etc.) of Tendered works for Period of Five Years on Procurement and Construction Basis. No Extra cost shall be paid separately.

1.17. During project Planning/Implementation if two units are installed at single location then the payment for installation of second unit will be taken 0.7 times (70%) of the quoted price of 1 bin by successful bidder in financial bid.

1.18. After successful installation of bin, based on monthly waste collection data, for any location, if frequency of waste collection is more than predefined intervals as per RFP, then bidder should have to install extra bin at that location and the payment shall be made as per rate quoted by successful bidder.

1.19. The price variation only applicable on Fuel Rates that can be considered if the Quarterly variation of fuel cost more than +/-5%. If the rates of fuel quarterly average more than 5% that shall be extra pay or deducted in Quaterly Payment.

1.20. It is considered that the rates quoted by the bidder for Opration of Moving vehicles per is an yearly basis, percentage for fuel cost will be taken 25% of the total quoted cost.

1.21. For example if the quarterly rate comes Rs.`A` than the fuel cost quarterly shall be taken 25% of Rs.`A` i.e. Rs.`B` (here B is 25% of A) and the variation will be calculated on Rs. `B`.

1.22. The fuel cost will be calculated 25% from the Quoted amount individually on yearly basis.

1.23. The calculation for Quarterly Average fuel price (In three months) is taken as follows-
For Example-

- i) Fuel price P Rs. for 'N' days
 - ii) Fuel price Q Rs. for 'M' days
 - iii) Fuel price S Rs. For 'O' days
- Since NDays+MDays+ODays =90Days
(three months)

$$\text{Quarterly average fuel price} = \left[\frac{(P \times N) + (Q \times M) + (S \times O) + \dots n}{90 \text{ Days}} \right]$$

Note- Days N/M/O shall be zero

1.24 The Operation and maintenance payment shall be Paid on Quaterly basis.

1.25 IT Engineer will also deploy at BSCDCL's Control command center for controlling the movement, record, tracking the vehicle, and preparation of report of daily basis work and same shall be submit to BSCDCL Daily and monthly basis.

- 1.26 The work Space for workshop, vehicle standing, stock area for spare parts etc. shall be provide by BSCDCL free of cost, development of that area shall be done by successful bidder. No extra cost shall be paid for developepment work.
- 1.27 The Movement of Vehicle shall be started for collection after the Installed bin is fill by municipal waste and sensor shall indicate to collect the waste. There is no movement occurs without any prior information and instruction from Engineer-in-charge of BSCDCL.
- 1.28 The Vehicle, Compactor & Crane shall be assemble by the Successful bidder by his own cost.

SECTION-7

**TECHNICAL
SPECIFICATIONS
&
LIST OF APPROVED MAKES**

SPECIFICATIONS-

This section contains the specifications for proposed work and shall be read in conjunction with the various other sections forming the Contract namely, Instructions to Tenderers, General Conditions, Special Conditions, Bill of Quantities, Drawings and other related documents mentioned in this Tender Document together with any Addendum issued thereto.

1. Technical Specification of underground smart bins

- a) **Supply, delivery, installation of a set of two units of Modern fully Underground Waste Collection Bins each comprising of capacity of 3 cum at a designated single location as per requirement.**
 - b) **Supply, delivery, installation of single units of Modern fully Underground Waste Collection Bins each comprising of capacity of 3 cum at a designated location as per requirement.**
 - c) **Supply, delivery, installation of single units of Dual Compartment Modern fully Underground Waste Collection Bins each comprising of capacity of 3 cum(2x1.5m3) at a designated location as per requirement.**
- ii) The entire system is in accordance to the standard EN13071-1 EN 13071-2 and the by an accredited domestic or foreign laboratory shall be provided.
 - iii) Supply and erection of international standard underground waste collection bins made of galvanized steel installed in reinforced cement concrete cases with a minimum 90 mm thickness, having water proof, closed construction. The Intake columns and the below container shall be lifted with a knuckle boom crane which is attached with a 2 (two) hook lifting and emptying device.
 - iv) All parts of container and all other steel frame are required to be steel plate with galvanized steel.
 - v)
 - vi) The container must be suitable for collecting municipal solid waste especially for wet/bio-degradable / organic waste and non-biodegradable waste with an opening suitable to receive the solid waste by the user / municipal worker at ward / street-level and for door-to-door collection from households and commercial establishments. The entire bin should be free from fire risk, vandalism and be safe and should provide safety.
 - vii)
 - viii) The Space on the pillar/intake columns may be so designed that it be used for running awareness among the users / citizen for safe garbage disposal. The desired colours and logo's, are to be

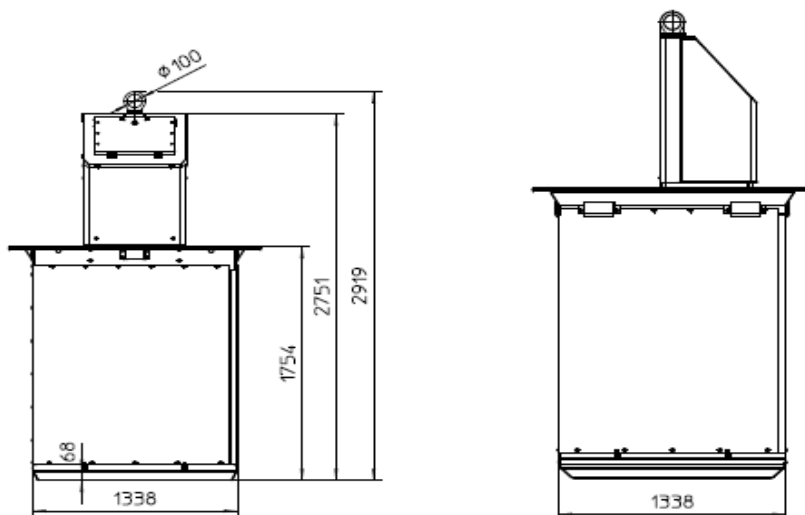

Figure 1: Details of 3cu.m. Fully Underground Bin

supplied as per the requirements of tender inviting authorities. The pillar/ intake column should have an opening facility, so that the rickshaw, hand cart puller/ sweeper/ can dispose the MSW directly to the intake pillar.

ix) Material Specifications:

The minimum material specifications areas follows:

For the container:

- Side walls made of 2 mm galvanized MS sheet according to DIN S235JR
- Bottom frame made of 4 mm hot-dip galvanized steel sheet according to DIN S235JR
- Trap doors made of 3 mm hot-dip galvanized steel sheet according to DIN S235JR
- Intake Column is modularly build and made from galvanized steel with additional powder coating or spray painting
- Bins are manufactured according to DIN ISO 2768-1

3 Concrete Bunker

The concrete bunker is rectangular in shape, comprising a base, two sidewalls and two end walls. All of the walls possess recesses to house elements of the opening and closing system and the raised parts of the polyethylene container. The base has a depression for collection of liquids or cleaning materials. The structural calculations of the bunker, actuating actions were designed in accordance with the prevailing standards.

- Inner height of a 3m³ bunker: 1.8 m
- Height of the external finishing of platform: 20 cm
- Total height of the external underground container (Throw in column): 1.0 m

Necessary Earth work excavation shall be carried out in all types of soil including Bituminous/ Paved Area/ CC road cutting for seating of RCC Trough / RCC Bunker with M-30 grade mix, over 1:3:6 PCC, the RCC Trough/ RCC bunker shall be with required steel reinforcement and the edges are secured by MS angles on all four sides at the top. The RCC trough/ RCC Bunker shall be cast in-situ or precast in nature.

A concrete platform of CC not less than 1:2:4 with 20 mm and down size jelly shall be constructed at ground level on firm ground and provided with paver blocks / anti-skid tiles to give good aesthetic appearance (Makes and material shall be approved by Engineer-in-Charge).

The gap around the RCC trough/ RCC bunker shall be filled with excavated available soil and the remaining debris shall be removed from the location and the location shall be kept clean and tidy. The excavation and platform shall be constructed in such a way that it shall have a clearance of 500 mm from either side.

Installation of Underground Bins

The installation procedure comprises following steps.

- Pit excavation
- Construction of concrete foundation followed by The concrete bunker is rectangular in shape, comprising a base, two side walls and two end walls
- Loose filling and closing of the pit surroundings and installation of the container
- Rebuilding of surroundings/pavement as per the requirement of location.

Concrete bunker cover

This item is made of laminated steel plate and designed in order not to allow the entry of liquids into the underground bins. The lid with a lock is used to lock the raise including hinges, gas cylinders which are necessary to help the operator to raise and lower the lid of underground container. It ensures tightness of the underground container when closed with top layer of anti-skid material or equivalently matching to the pavement. The cover, the metals, base of the cover, shock absorber supports and plates has an anti-corrosion treatment and protection. All bolts and sleeves are made of stainless steel. The hinges have brass bushings. The surface is protected against oxidation.

Mechanism for opening and closing the concrete bunker cover is designed to be comfortably operated by a single person. The cover is fitted with hinges which allow it to open, turning on the respective rim of the concrete bunker to an angle close to 90 degrees. The cover is opened by means of a key. Immediately after the tab which keeps the system closed is turned, the cover begins to open automatically. After several centimeters, the operator assists the opening of the cover and its retention at the end of this movement. The basic effort of opening the cover is undertaken by two cylinders connected to two supports located inside the concrete bunker, and two other identical supports located on the cover.

The cover is closed manually. The operator assists initially, facilitating the first part of the movement. The cover continues to close automatically until a semi-closed position. The stainless steel tab attached to the cover then turns, entering the recess in the rim attached to the concrete bunker.

Bin Leveling Sensor including automated software

The fill level management and route planning is carried out by a system that uses an ultrasonic sensor and a web portal to provide information on the state of filling in each container. Each sensor is protected against impacts and placed inside the container. In a specific time the system sends by GSM the filling level information to the web platform. Data from the various sensors allow the manager to allocate resources and program the required output in an economic and environmentally sustainable way.



Sensors for Measuring Waste Filling

The mode “Route Planning” shows the containers to collect and the most efficient route. This information can be sent to a mobile device (Smartphone or Tablet) to help the driver. With this system it is possible to produce different reports on filling levels of the different containers: the number of collections, the historical data and other useful information to manage a more efficient collection.

Technical Specification of Sensor

Sr. No	Parameter	Value
	Sensor Type	Ultrasonic
	Signal distribution Technology	GPRS over GSM (Quad band – 850/900/1800 MHz) with internal SIM Card. No user accounts required.
1	Dimensions	Width x Height 90mmx67 mm
2	Standard Thread Mount	1 inch NPT
3	Container Depth max.	3.0 meters
4	Min. Measurement	15 cm
5	Temperature Rating	-30 C to +70 C (operation)
6	Battery Life	Upto 10 years
7	Protection rating	IP66
8	Shocks	100geach Axis(EN60058-2-27/F4)

9	Impact	IK10 (EN50102/F4)
10	Recycling	ROHS Compatible
11	Housing	High-density IP66 polyethylene (HDPE)
12	Communications	EGSM(850/900/1800/1900MHz)
13	CE Certification	CE0980 Articles3.1(a)(b), 3.2 (inside)
14	FCC Compliance	FCCID:UDV-0912142009007 (inside)

Monitoring System Specification

A comprehensive bin monitoring system to be implemented having following features.

- System Hosting: Hosting on cloud, adequate security measures are taken and assured to prevent any breach. Integration with command centre to be done as and when available.
- Dashboard Module:
 - Dashboard Module should give a quick and easy view to know overall fleet status on real time basis. It should display status information of all vehicles i.e. Running, Idle or Standby.
 - It should give alert message if BLS device gets disconnected from a bin.
 - Dashboard should have search parameter where different searches i.e. Bin Number wise, Location wise, Fill level of bin wise searches can be done.
 - It should also give an indication regarding the status of the bin
 - There should be provision to see a particular bin on map
 - Live Bin tracking
 - The live bin view also should have facility for various alerts i.e. fill levels, temperature/ battery level, no communication from device.
 - In live map view, real time location of bin
- Reports
 - Several Customized MIS Reports should be available (example: preventive maintenance reports, incident reports etc.)
 - Report on bin to bin collection as well as Bin management.
 - In addition, following reports also should be available.
 - ✓ Daily Bin fill status
 - ✓ Daily bin empty status
- Admin
 - Admin Module should have facility to add, edit and delete the user. The rights of information to be viewed by the user can also be controlled by the admin.
 - The admin can assign bin to ward, zone and selected integrator.
- Mapping Platform
 - Google Maps or suitable maps may be used as a mapping platform. The successful Bidder should ensure that street level accuracy is obtained in this platform.
 - The successful Bidder will have to define all the Geo-locations, Routes, for mapping platform.
 - Updating / changes of Routes, Geo-locations also will be carried out by the Successful Bidder as & when required.
 - In future, if BSCDCL gets GIS based street level map, the Successful Bidder will have to integrate and synchronize it with existing system and Google Maps may discontinue.

Waste Collection Vehicles and its Attachments

The waste collection vehicles are the trucks with capability to install PTO gear box on chassis for installation of fully automated crane and mobile compactor Unit. There are two types of waste collection vehicles Rear-loading vehicles and Top-loading vehicles are used for waste collection purpose.

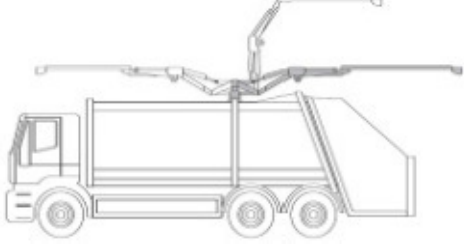
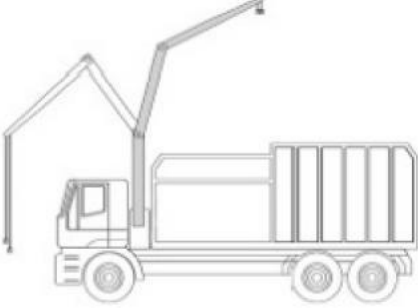
	
Rear-loading vehicles with Mobile compactor	Top-loading vehicles with Mobile compactor

Waste Collection vehicles

Its Special purpose Vehicle Mounted Refuse Compactor Machine, Mounted on 16 Ton to 25 Ton GVW Chassis with PTO and Hydraulic Assembly. It also includes 10 ton/meter crane which can be mounted on truck which can be operated directly from driver cabin. A Crane with Lifting Hook, Radio Remote Control, Overload Protection, Hydraulic Boom, Telescopic Outriggers medium as per the below mentioned Technical Specifications.

Crane

Knuckle boom truck mounted Crane with remote control operation to lift the Underground Bins. The CRANE must have minimum Lifting Capacity of 1.5 Tons from approx. 6 Meter horizontal & vertical outreach along with manual outriggers hydraulic stabilizers, including sub-frame fabrication, mounting & installation and commissioning on compactor Truck.

Knuckle Boom truck mounted Crane with the following specification	Palfinger/Hyva/Hiab make or similar 9.5tm crane
Min. lifting moment	9.5 mt/93.5 kNm
Min. lifting capacity	5700 kg/55.9 kN
Min. Hydraulic outreach	12.4 meters
Min. Slewing angle	400°
Min. Stabilizer spread	3.3 m standard and 5.6 m max.
Min. Width folded	2.5 m
Min. Operating pressure	315 bar

Crane should have remote control and manual overdrive so the operator can operate the crane safely. Cranes shall be securely fitted between the truck cabin and compactor body with required reinforcements so that the truck chassis or the sub frame is not damaged or cracked in due course of operations.

Compactor Truck for Collection of Municipal Solid Waste

Commissioning of Compactor Truck with company fitted PTO gear box on 16 Ton GVW Chassis (TATA/AshokaLaylend/Eicher/Mahindra or similar) with cabin and hydraulically controlled compactor body for easy collection and disposal of municipal solid waste collection along with an in-built bin washing system for regular cleaning of underground bins. The compactor body must be so fabricated that it should be intended to fit a crane between the driver cabin and compactor body suitable for emptying the underground bins through standard compactor bin lifting device. The truck used for collection of waste from smart bins to designated location must be new and it has been approved by BSCDCL.

SPECIFICATION OF COMPACTOR TRUCK CHASSIS & BODY FOR COLLECTION OF MUNICIPAL SOLID WASTE

Truck Chassis and Compactor with following Body Specification Details	TATA/Ashok Leyland/Eicher/Mahindra or Similar
Truck:	
Engine	6 Cylinders Inline
Loading Capacity (GVW)	16 Tonnes or above
Axles	Heavy duty, Forged 1 beam, Reverse Elliot Type
Payload	10 Tonnes or above
Wheelbase	4800mm or above
Steering	Power Steering 20.2:1
Cabin & Chassis	YES
Emissions	BSIV or as applicable at the time of supply
PTO	As recommended or supplied by the truck chassis manufacturer
Compactor Body:	
Main Container Body	St-52/Equivalent Side Sheet Thickness:3mm Roof Sheet Thickness:3mm Floor Sheet Thickness:5mm
Refuse Ejection Barrier	St-52/Equivalent of 3mm
Tailgate Floor	Hardox 400/Equivalent of 5mm
Sweeping plate	Hardox 400/Equivalent of 5mm
Body Volume	12 - 14 m ³
Type of operation	Loading with hydraulic operation
Hydraulic Cylinders	9 double acting cylinders for all operation including bin lift & emptying
Hydraulic Pump	Gear/Vane pump (52 cc/rev)
Hydraulic Tank	60 to 80 litres
Operating Pressure of the System	165 – 175 bar
Operating Pressure of the Pump	165 – 175 bar
Max. peak pressure produced by pump	275 bar
Hydraulic Oil Specifications	ISO grade 68 AW
Leachate Collection	Built in sump for collection of leachate
Hydraulic fitting, rubber and other metal fittings	All complete
Hydraulic Tank with Structure	Complete
Check Valve, Central Valve and Compound Valve	As required
Channel size (Bottom)	4 x 6"
Hydraulic Oil	60 - 80 Litres
Complete Painted Body	Colour as specified by the tender inviting authority
Accessories	Bin Washing System
Pump	Jetting pump driven by auxiliary engine
Flow Rate	15 Lpm
Pressure	96 bar
Gun	Pressurewasher gun
Water Tank	1000 litre

T

he Tipper Truck, Body and Crane must consist of the following:

1. Truck chassis with suitable sub-frame fabrication.
 2. Knuckle Boom Truck mounted Crane with remote.
 3. Compactor -
 - a. Main body or Container.
 - b. Hopper.
 - c. Packing Mechanism
 - d. Refuse Ejection Barrier
 - e. Hydraulic Operating System
 - f. Bin Washing System
 - g. Control Station
- a) Main Body or the Container:**
- i. Smooth and rounded side wall and roof design
 - ii. Constructed with structural steel with solid sub frame
 - iii. Compactor container body with good aesthetics look and improved features.
 - iv. The body must be with combination of Ejector plate, Hopper, Sweeper, Packer and Bin Lifters.
- b) Hopper:**
- i. Optimized 1.6 or more m³ swept volume capacity to reduce wear & tear and fuel consumption
 - ii. Full 1.9m uncluttered loading width.
 - iii. Integral full height body hopper seal fitted to prevent liquid leakage from bottom edge and hopper sides
 - iv. High wear resistant steel for hopper plate.
- c) Packing Mechanism:**
- i. Proven two-plate fabricated packer/sweeper design
 - ii. Sweeper plate manufactures using high tensile abrasion resistant steel.
 - iii. Packing mechanism by dual packer cylinder and dual sweeper cylinder.
- d) Hydraulic operating system:**
- i. Rugged PTO mounted standard gear pump
 - ii. Body mounted tank
 - iii. Pneumatic throttle control system with push button provided in chassis cabin
 - iv. Separate 2 spool hydraulic directional control valves with manual levers control for all system function.
 - v. Over centre valve on each tailgate cylinder to avoid sudden fall of tailgate with in raised condition.
 - vi. Body side mounted hopper lift cylinders

e) Bin Washing System:

- i. Jet spray system to be provided to clean bins, equipment and work place.
- ii. Jetting pump driven by auxiliary engine to be provided spray gun
- iii. Flow rate & Pressure – 15Lpm and 96 bar pressure
- iv. 1000 litres water tank to be fitted in the compactor truck

f) Control Station:

- i. Compaction mechanism control station to be provided at the rear of the vehicle. Control station must be location outside the body to enable the operator to supervise the whole operation.
 - ii. External discharge control station to be provided at the front of the body for ejection mechanism and lifting the DISMANTLING AND DEMOLISHING
-

List of Approved Makes

S. No.	NAME OF MATERIAL	APPROVED MAKE
1	Cement	L&T , Ultratech,Binani,MyCem,ACC
2	Reinforcement Steel / Structural steel	TISCO, SAIL, TSRM, VIZAG STEEL,JISCO
3	Tiles	Johnson / Kajaria / Somany/ Nitco/Regency
4	Acrylic emulsion paints / Distempers / synthetic enamel paint	Johnson & Nicholson / Garware / Berger / Asian paints
5	Cement paint	Snow cem / Asian paint / Berger / Nitco
6	Paver block	Designer pavings / Vibrant besser / Aeons / Hicon / Malu / Prathisai / shanFlyash/Nitco or any other meeting our specifications as per attachment.
7	PVC / UPVC pipe	Supreme / Prince / Finol
8	GI pipe / MS pipe	Tata / Zenith / GST / Jindal
9	Waterproofing compound	Acco proof ,Pidilite , Cico ,Impermo/Fosroc
10	Anchor bolts	Conforming to IS:2062 as approved by EIC
11	Nuts & bolts	TVS, GWK, UNBREAKO/As per the approval EIC
Note :	Regarding selecting the make against each item among the approved makes as specified above, final approval shall be taken by EIC BSCDCL	

SECTION-8 DRAWINGS

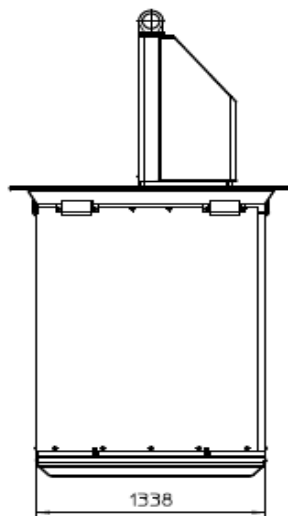
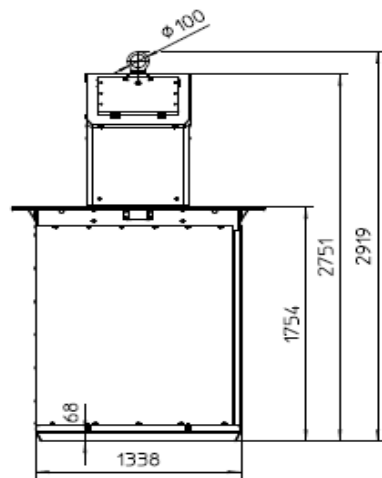

SECTION-9

BILL OF QUANTITY

(ATTACHED

SEPARATELY IN THE

FINANCIAL BID SHEET)